



X440T MODEL

2025 HARLEY-DAVIDSON® OWNER'S MANUAL

PREFACE

Thank you for selecting the **Harley-Davidson X440T** by Hero MotoCorp. We wish you many miles of continued riding pleasure in the years ahead.

We at Hero MotoCorp, are committed to demonstrate excellence in our environment performance on a continual basis, as an intrinsic element of our corporate philosophy. To achieve this we commit ourselves to continue product innovations to improve environment compatibility, comply with all applicable legislation including environment legislation and strengthen the green supply chain.

Your **H-D X440T** is conforming to latest BS-VI OBD Stage II-B regulation for emission, safety & noise levels. We are also using non asbestos brake shoes/pads and engine gaskets which are environment friendly in nature.

The **H-D X440T** is fitted with a lighting feature known as “Automatic Headlamp ON”. The feature is mandated for all 2 Wheelers by Ministry of Road Transport & Highways (Government of India) vide notification GSR 188 (E) dated 22nd February 2016. This feature helps in conspicuity for improving rider safety. The headlamp of the **H-D X440T** will always be lit ON when the engine gets ON.

This booklet is your guide to the basic operation and maintenance of your new **Harley-Davidson X440T** by Hero MotoCorp. Please take time to read it carefully. As with any fine machine, proper care and maintenance are essential for trouble-free operation and optimum performance.

Your Authorized dealer will be glad to provide further information or assistance and is equipped to handle your future service needs.

Let us make this world a safer, healthier and more environment friendly place.



NOTE

ALL INFORMATION, ILLUSTRATION, PHOTOGRAPH, DIRECTIONS, SPECIFICATIONS AND OTHER CONTENTS COVERED IN THIS OWNER'S MANUAL ARE BASED ON THE LATEST PRODUCT INFORMATION AVAILABLE AT THE TIME OF ITS PUBLISHING APPROVAL, AND THE ACCURACY OR CORRECTNESS OF THE SAME IS NOT UNDERTAKEN OR GUARANTEED.

HERO MOTOCORP LTD RESERVES THE RIGHT TO MAKE CHANGES IN ITS CONTENTS AT ANY TIME WITHOUT NOTICE AND/OR INCURRING ANY OBLIGATION, WHATSOEVER. NO ONE IS ALLOWED TO REPRODUCE ANY PART OF THIS PUBLICATION WITHOUT OBTAINING PRIOR WRITTEN PERMISSION FROM HERO MOTOCORP LTD.

*ACCESSORIES SHOWN MAY NOT BE THE PART OF STANDARD FITMENT. IT IS OUR ENDEAVOUR TO CONSTANTLY IMPROVE OUR PRODUCTS. THIS COULD LEAD TO CHANGE IN PRODUCT SPECIFICATIONS WITHOUT NOTICE. **'HARLEY-DAVIDSON X440T'** COMPLIES WITH THE LATEST EMISSION NORMS.*



TABLE OF CONTENTS

INTRODUCTION

Your Owner's Manual	1
We Care About You	1
Customer Service Assistance	1

SAFETY FIRST

Safety Definitions.....	3
Safe Operating Rules.....	3
General	4
Operation	4
Steering and Handling	5
Accessories and Cargo.....	6
Tyres	7
Towing and Trailering	7
Fuel and Exhaust	8
Brakes	9
Battery	10
Hazardous Materials.....	11
Maintenance.....	11
Parts and Accessories	11
Anti-Lock Brake System (ABS)	12
Rules of the Road.....	12
Noise Control System	13

YOUR VEHICLE

Vehicle Identification.....	15
Variant Details	16
Primary Controls and Service Components.....	17

SPECIFICATIONS

Specifications	21
Tyres	21
Weights and Dimensions	21
Capacities	22
Engine and Transmission	22
Electrical.....	23

BEFORE RIDING

Removing Vehicle from Storage.....	25
Pre-Ride Checklist.....	25
Break-in Riding Rules	26
Filling the Fuel Tank	27
Fuel System Information	29
Catalytic Converter	30
ABS Brake System Identification.....	30
Tyres	31
Adjusting Mirrors.....	35
Operating Side Stand.....	35
Adjusting Shock Absorber.....	36

OPERATION

Controls, Instruments And Switches	39
Steering Lock.....	41
Instruments	42
Indicators.....	60
H-D Connect – App Overview.....	64
Left Handlebar Control Switches.....	68

TABLE OF CONTENTS

Right Handlebar Control Switches	72	Drive Chain Slider Inspection.....	106
USB Charger	74	Brakes	106
Panic Brake Signal System.....	75	Main/Side Stand Lubrication.....	110
Traction Control.....	75	Nuts, Bolts & Fasteners	110
Starting the Engine	76	Battery.....	111
Braking.....	78	Fuse Replacement	114
Riding.....	80	Headlamp Focus Adjustment.....	115
AFTER RIDING		Gearshift Pedal Adjustment	116
Cleaning And Washing Of Vehicle	83	Catalytic Converter.....	117
Storing Vehicle	83	Evaporative Emission Control System	118
MAINTENANCE		Polishing Of Vehicle.....	118
Maintenance	85	TROUBLESHOOTING	
Safety Precautions	86	Starting Trouble - Engine Does Not Start.....	119
Maintenance Schedule.....	87	Engine Starts But Stalls	121
Tool Kit	90	Poor Pick-Up	121
First Aid Kit	91	Electrical System.....	122
Spark Plug Inspection.....	92	ROAD SIGN AND NAVIGATION	
Engine Oil.....	93	Road Sign.....	123
Engine Oil Filter Element	96	Navigation	125
Engine Oil Cooler.....	97	WARRANTIES	
Air Cleaner	97	Scope Of Warranty	127
Valve Clearance	100	Limitations Of Warranty	128
Clutch Lever Free Play.....	100	Battery Warranty Period	130
Drive Chain Slackness.....	102	Emission Warranty	131
Drive Chain Slider Inspection.....	106		

YOUR OWNER'S MANUAL

We Care About You

Welcome to the Harley-Davidson Motorcycling Family! When enjoying your **Harley-Davidson X440T** by Hero MotoCorp, be sure to ride safely, respectfully and within the limits of the law. Always wear a helmet, proper eyewear and protective clothing, and insist your passenger does too. Never ride while under the influence of alcohol or drugs. Know your **H-D X440T** and read and understand your Owner's Manual from cover to cover.

This manual has been prepared to acquaint you with the operation, care and maintenance of your **H-D X440T** and to provide you with important safety information. Follow these instructions carefully for maximum vehicle performance and for your personal vehicle safety and pleasure. Your Owner's Manual contains instructions for operation and minor maintenance. Major repairs are covered in the Harley-Davidson Service Manual. Such major repairs require the attention of a skilled technician and the use of special tools and equipment.

Your dealer has the facilities, experience and Genuine parts necessary to properly render this valuable service.

CUSTOMER SERVICE ASSISTANCE

Most sales or service issues are resolved at the dealership.

1. Discuss your problem with the appropriate personnel at the dealership in the Sales, Service or Parts area. If that proves unsuccessful, speak to the owner of the dealership or the general manager.
2. If you cannot resolve the issue with the dealership, **Contact Harley-Davidson Business Unit at:** Hero MotoCorp Limited, The Grand Plaza, Plot No.2, Nelson Mandela Road, Vasant Kunj - Phase -II, New Delhi - 110070.

Contact Number : 1800 103 8903

Website : Rideindia@harley-davidson.com



Table 1. Vehicle and Personal Data

PERSONAL INFORMATION	DEALER INFORMATION
Date of Purchase:	
Name:	Name:
Address:	Address:
Address:	Address:
Vehicle Identification Number:	Sales Contact:
Key Number:	Service Contact:



SAFETY DEFINITIONS

Statements in this manual preceded by the following words are of special significance:

WARNING

WARNING indicates a potentially hazardous situation which, if not avoided, could result in death or serious injury.

CAUTION

CAUTION indicates a potentially hazardous situation which, if not avoided, may result in minor or moderate injury.

NOTICE

NOTICE indicates a potentially hazardous situation which, if not avoided, may result in property damage.

NOTE

Refers to important information and is placed in italic type. It is recommended that you take special notice of these items.

SAFE OPERATING RULES

WARNING

H-D X440T is different from other vehicles. They operate, steer, handle and brake differently.

Unskilled or improper use could result in loss of control, death or serious injury.

- Take a rider training course.
- Read Owner's Manual before riding, adding accessories or servicing.
- Wear a helmet, eye protection and protective clothing.
- Never tow a trailer.

H-D X440T are for On-Road Use Only.

Your **H-D X440T** is not equipped with a spark arrester. The **H-D X440T** is designed to be used only on the road. Operation or off-road usage in some areas may be illegal. Obey local laws and regulations.



General

WARNING

Consult an authorized dealer regarding any questions or problems that occur in the operation of your H-D X440T. Failure to do so can aggravate an initial problem, cause costly repairs, cause an accident and could result in death or serious injury.

- Make sure all equipment required by federal, state and local law is installed and in good operating condition.
- Know and respect the rules of the road. Read the safety information that is provided by your state or regional traffic authority.
- Protect your **H-D X440T** against theft. Lock the front fork. Remove the key when parking your **H-D X440T**.

WARNING

Do not add sidecar to the H-D X440T. Operating H-D X440T with sidecar can cause loss of vehicle control, which could result in death or serious injury.

Operation

Before operating your new **H-D X440T**, it is your responsibility to read and follow the operating and maintenance instructions in this manual and follow these rules for your personal safety.

- Before starting the engine, review the pre-ride checklist ([page 25](#)).

WARNING

Striking an object, such as a curb or pothole can cause internal tyre damage. If an object is struck, have the tyre inspected immediately inside and out by an Authorized dealer. A damaged tyre can fail while riding and adversely affect stability and handling, which could result in death or serious injury.

WARNING

Travel at speeds appropriate for road and conditions and never travel faster than posted speed limit. Excessive speed can cause loss of vehicle control, which could result in death or serious injury.

CAUTION

Avoid keeping any cloth or flammable object between or around the hot parts (muffler, oil cooler, engine).



- Do not drive faster than the conditions permit and in no case exceed the legal speed limit while driving. Always reduce speed when poor driving conditions exist. High speed increases the influence of any other condition affecting stability and increases the possibility of loss of control.
- Pay strict attention to road surfaces and wind conditions and keep both hands on the handlebar grips at all times when riding the vehicle. Any two wheeled vehicle may be subject to upsetting forces such as wind blasts from passing trucks, holes in the pavement, rough road surfaces, rider control error, etc. These forces may influence the handling characteristics of your
- **H-D X440T**. If this happens, reduce speed and guide the vehicle with a relaxed grip to a controlled condition. Do not brake abruptly or force the handlebar. This may aggravate an unstable condition.
- New riders should gain experience under various conditions while riding at moderate speeds.
- Operate your **H-D X440T** defensively. In an accident, a vehicle does not afford the same protection as an automobile.
- It is the rider's responsibility to instruct passengers on proper riding procedures.
- Do not allow other individuals to operate your **H-D X440T** unless they are experienced, licensed riders and are thoroughly familiar with the operation of the vehicle.

WARNING

Front and/or rear guard(s) can provide limited leg and cosmetic vehicle protection under unique circumstances such as Fall over while stopped, very slow speed slide, etc. It is not made or intended to provide protection from bodily injury in a collision with another vehicle or any other object.

Steering and Handling

WARNING

Do not operate vehicle with forks locked. Locking the forks restricts the vehicle's turning ability, which could result in death or serious injury.

WARNING

Regularly inspect shock absorbers and front forks. Replace leaking, damaged or worn parts that can adversely affect stability and handling, which could result in death or serious injury.



⚠ WARNING

Do not operate H-D X440T with loose, worn or damaged steering or suspension systems. Contact an Authorized dealer for repairs. Loose, worn or damaged steering or suspension components can adversely affect stability and handling, which could result in death or serious injury.

⚠ WARNING

Do not open storage compartments while riding. Distractions while riding can lead to loss of control, which could result in death or serious injury.

⚠ WARNING

When riding on wet roads, brake efficiency and traction are greatly reduced. Failure to use care when braking, accelerating or turning on wet roads can cause loss of control, which could result in death or serious injury.

Accessories and Cargo

⚠ WARNING

Do not exceed the H-D X440T Gross Vehicle Weight Rating (GVWR) or Gross Axle Weight Rating (GAWR). Exceeding these weight ratings can lead to component failure and adversely affect stability, handling and performance, which could result in death or serious injury.

- GVWR is the sum of the weight of the vehicle, accessories and the maximum weight of the rider, passenger and cargo that can be safely carried.
- GAWR is the maximum amount of weight that can be safely carried on each end of the vehicle.
- Keep cargo weight concentrated close to the vehicle and as low as possible.
- Distribute weight evenly on both sides of the vehicle.
- Do not load bulky items too far behind the rider or add weight to the handlebars or front forks.



- Do not exceed maximum specified load in each saddlebag (if equipped).
- Luggage racks (if equipped) are designed for lightweight items. Do not overload racks.
- Make sure cargo is secure. Make sure the cargo does not shift while riding and check the cargo periodically. Accessories that change the operator's riding position may increase reaction time and affect handling of the vehicle.

Tyres

WARNING

Be sure tyres are properly inflated, balanced, undamaged, and have adequate tread. Inspect your tyres regularly and see an Authorized dealer for replacements. Riding with excessively worn, unbalanced, improperly inflated, overloaded or damaged tyres can lead to tyre failure and adversely affect stability and handling, which could result in death or serious injury.

WARNING

Replace punctured or damaged tyres. In some cases, small punctures in the tread area may be repaired from within the removed tyre by an Authorized dealer.

Towing and Trailering

WARNING

Do not pull a trailer with a vehicle. Pulling a trailer can cause tyre overload, damage and failure, reduced braking performance, and adversely affect stability and handling, which could result in death or serious injury.

WARNING

Do not tow a disabled vehicle. Towing can adversely affect stability and handling, which could result in death or serious injury.

Never tow a trailer.



Fuel and Exhaust

WARNING

Stop the engine when refueling or servicing the fuel system. Do not smoke or allow open flame or sparks near petrol. Petrol is extremely flammable and highly explosive, which could result in death or serious injury.

WARNING

Avoid spills. Slowly remove filler cap. Do not fill above bottom of filler neck insert, leaving air space for fuel expansion. Secure filler cap after refueling. Petrol is extremely flammable and highly explosive, which could result in death or serious injury.

- Refuel in a well-ventilated area with the engine off.
- Remove the fuel filler cap slowly.
- Do not fill fuel tank above the bottom of the filler neck insert. Leave air space to allow for fuel expansion.

WARNING

Avoid contact with exhaust system and wear protective clothing that completely covers legs while riding. Exhaust pipes and mufflers get very hot when engine is running and remain too hot to touch, even after engine is turned off. Failure to wear protective clothing could result in burns or other serious injury.

WARNING

Do not run H-D X440T in a closed garage or confined area. Inhaling vehicle exhaust, which contains poisonous carbon monoxide gas, could result in death or serious injury.



Key

WARNING

A metal key holder or additional key in the key holder may damage the surfaces surrounding the ignition key area. It is advised to avoid the same.

Brakes

WARNING

Brakes are a critical safety component. Contact an Authorized dealer for brake repair or replacement. Improperly serviced brakes can adversely affect brake performance, which could result in death or serious injury.

WARNING

Apply front and rear brakes evenly. Favoring one brake accelerates wear and reduces braking efficiency. Operation with excessively worn brakes can lead to brake failure, which could result in death or serious injury.

WARNING

Contact with DoT 4 brake fluid can have serious health effects. Failure to wear proper skin and eye protection could result in death or serious injury.

- If inhaled: Keep calm, remove to fresh air, seek medical attention.
- If on skin: Remove contaminated clothing. Rinse skin immediately with plenty of water for 15-20 minutes. If irritation develops, seek medical attention.
- If in eyes: Wash affected eyes for at least 15 minutes under running water with eye lids held open. If irritation develops, seek medical attention.
- If swallowed: Rinse mouth and then drink plenty of water. Do not induce vomiting. Immediate medical attention required.



⚠ WARNING

DoT 4 brake fluid absorbs moisture from the atmosphere over time, changing the properties of the fluid. Check brake fluid moisture content at every service interval or annually (whichever comes first). Flush and replace the brake fluid every two years, or sooner if moisture content is 3% or greater. Failure to flush and replace fluid can adversely affect braking, which could result in death or serious injury.

To ensure the brake system is performing to design, check the moisture content of the brake fluid at every service interval or at least annually using a DoT 4 brake fluid moisture tester following the instructions included with the tool. Flush DoT 4 fluid every 2 years or sooner if the brake system fluid test shows moisture content is 3% or greater.

Battery

⚠ WARNING

Batteries contain sulfuric acid, which could cause severe burns to eyes and skin. Wear a protective face shield, rubberized gloves and protective clothing when working with batteries.

KEEP BATTERIES AWAY FROM CHILDREN.

NOTICE

It is possible to overload your **H-D X440T** charging system by adding too many electrical accessories. If the combined electrical accessories operating at any one time consume more electrical current than the vehicle's charging system can produce, the electrical consumption can discharge the battery and cause damage to the vehicle's electrical system. See an Authorized dealer for advice about the amount of current consumed by additional electrical accessories or for necessary wiring changes.



Hazardous Materials

CAUTION

Prolonged or repeated contact with used motor oil may be harmful to skin and could cause skin cancer. Promptly wash affected areas with soap and water.

Maintenance

WARNING

Perform the service and maintenance operations as indicated in the regular service interval table. Lack of regular maintenance at the recommended intervals can affect the safe operation of your H-D X440T, which could result in death or serious injury.

- A new H-D X440T must be operated according to the special break-in procedure. See Break-in Riding Rules (page 26).
- Proper care and maintenance, including tyre pressure, tyre condition, tread depth and proper adjustment to steering head bearings are important to stability and safe operation of the vehicle.

Parts and Accessories

WARNING

Use genuine H-D X440T parts and accessories that are specifically designed and manufactured by Hero MotoCorp. Using non-genuine parts or accessories can adversely affect performance, stability or handling, which could result in death or serious injury.

- Use only Hero MotoCorp approved parts and accessories. Use of certain other manufacturer's performance parts will void your H-D X440T warranty. See your Authorized dealer for details.

WARNING

Use Hero MotoCorp replacement fasteners. Aftermarket fasteners can adversely affect performance, which could result in death or serious injury.

- See your Owners Manual for proper torque values.
- After market fasteners may not have the specific property requirements to perform properly.



⚠ WARNING

See the Accessories and Cargo section in your Owner's Manual. Improper cargo loading or accessory installation can cause component failure and adversely affect stability, handling and performance, which could result in death or serious injury.

- Hero MotoCorp cannot test and make specific recommendations concerning every accessory or combination of accessories sold. Therefore, the rider must be responsible for safe operation of the vehicle when installing accessories or carrying additional weight.
- Additional electrical equipment may overload the electrical system possibly resulting in electrical system and/or component failure.

ANTI-LOCK BRAKE SYSTEM (ABS)

⚠ WARNING

If ABS lamp continues flashing at speeds greater than 5 km/h or remains on continuously, the ABS is not operating. The standard brake system is operational, but wheel lock up can occur. Contact an Authorized dealer to have ABS repaired. A locked wheel will skid and can cause loss of vehicle control, which could result in death or serious injury.

⚠ WARNING

ABS cannot prevent lockup of rear wheel due to engine braking. ABS will not aid in cornering or on loose/uneven surfaces. A locked wheel will skid and can cause loss of vehicle control, which could result in death or serious injury.

To operate vehicle equipped with an anti-lock brake system, see Brake System ([page 78](#)).

RULES OF THE ROAD

- Always sound your horn, use your turn signals and exercise caution when passing other vehicles going in the same direction. Never pass going in the same direction at street intersections, on curves or when going up or down a hill.
- At street intersections, give the right-of-way. Do not presume you have the right-of-way, as the other driver may not know that it is your turn.
- Always signal when preparing to stop, turn or pass.
- Promptly obey all traffic signs, including those signs used for the control of traffic at intersections. Always obey traffic signs near schools and at railroad crossings.



- When intending to turn, signal at least 100 ft (30.5 m) before reaching the turning point. If turning across an intersection, move over to the centerline of the street (unless local rules require otherwise). Slow down when entering the intersection and turn carefully.
- Never anticipate a traffic light. When a change is indicated from GO to STOP (or STOP to GO), slow down and wait for the light to change. Never run through a yellow or red traffic light.
- While turning, watch for pedestrians, animals, as well as vehicles.
- Do not leave the curb or parking area without signaling.
- Make sure that your way is clear to enter moving traffic. A moving line of traffic always has the right-of-way.
- Make sure that your license plate is installed in the position specified by law. Make sure that your license plate is always clearly visible. Keep the license plate clean.
- Ride at a safe speed that is consistent with the type of highway you are on. Pay strict attention to whether the road is dry, oily, icy or wet.

- Watch for debris such as leaves or loose gravel.
- Weather and traffic conditions on the highway dictate adjusting your speed and driving habits accordingly.

NOISE CONTROL SYSTEM

Tampering

Removal or replacement of any noise control system component may be prohibited by law. This prohibition includes modifications made prior to vehicle sale or delivery to the ultimate purchaser. Use of a vehicle on which noise control system components have been removed or rendered inoperative may also be prohibited by law.



NOTES



VEHICLE IDENTIFICATION

Vehicle Identification Number (VIN)

Location

See Figure 1. The full 17-digit VIN is stamped on the right side of the frame near the steering head.

NOTE

Always give the full 17-digit Vehicle Identification Number when ordering parts or making any inquiry about your H-D X440T.

Engine No.

Location

See Figure 2. The full 14-digit engine no. is stamped on the lower side of the left crankcase.



1. Stamped VIN

Figure 1. VIN Location



2. Stamped engine number

Figure 2. Engine Number Location



VIN: MBLYGU16#####

MBL	YGU16	#	#	#	#	#####
Manufacturer code	Vehicle Description	Check Digit	Model Year	Plant Code	Month of Manufacturing	Production Serial Number

Engine No.: YG01AK#####

YG01AK	#	#	#	#####
Engine Description	Year of Manufacturing	Assembly Plant	Month of Manufacturing	Serial Number

VARIANT DETAILS

Variants	VIN	Engine
Cruiser/Roadster/Non Connected	YGU16	YG01AK



PRIMARY CONTROLS AND SERVICE COMPONENTS

Familiarize yourself with the location of all the controls and service components on your **H-D X440T**.

NOTE

Illustrations and photos are for general reference only. Controls and service components shown are general locations and representations that do not show a specific model of vehicle.

Hero MotoCorp *reserves the right to change specifications, equipment or designs at any time without notice and without incurring any obligation.*

See Figure 3 for rider controls and service components accessible when seated.

See Figure 4 for rider controls and service components accessible from the right.

See Figure 5 for rider controls and service components accessible from the left.





- | | |
|-------------------------------------|---|
| 1. Horn switch | 9. Ignition switch with key |
| 2. Turn signal switch | 10. Front brake master cylinder/Reservoir |
| 3. Rear view mirror | 11. Hazard switch |
| 4. Clutch lever | 12. Integrated start-kill switch |
| 5. Headlamp dimmer/Pass lamp switch | 13. Front brake lever |
| 6. Home screen navigator control | 14. Electronic throttle grip |
| 7. USB charger | 15. QR code/E20 sticker |
| 8. Meter console | 16. Fuel tank cap |

***Accessories and features shown may not be part of standard fitment.**

Figure 3. Controls and Service Components Accessible When Seated.





- | | | |
|--------------------------------|------------------------------------|-----------------------------------|
| (1) Rear disc | (7) Front brake caliper assembly | (12) Battery compartment (inside) |
| (2) Rear brake fluid reservoir | (8) Front disc | (13) Rear grip |
| (3) Rear brake master cylinder | (9) Front turn signal lamp | (14) Licence plate lamp |
| (4) Rider footrest | (10) Air cleaner assembly (inside) | (15) Rear brake caliper assembly |
| (5) Brake pedal | (11) Seat | (16) Exhaust muffler |
| (6) Oil level window | | |

***Accessories and features shown may not be part of standard fitment.**

Figure 4. Controls and Service Components Accessible from the Right





- | | | |
|---------------------------|---|----------------------------|
| (1) Oil cooler | (6) Pillion footrest | (11) Fuse box (inside) |
| (2) Starter motor | (7) Saree guard with women pillion step | (12) Left side cover |
| (3) Gearshift pedal | (8) Rear turn signal lamp | (13) Side stand switch |
| (4) Main stand (Optional) | (9) Tail/Stop lamp | (14) Headlamp |
| (5) Side stand | (10) Rear shock absorber | (15) Side reflex reflector |

***Accessories and features shown may not be part of standard fitment.**

Figure 5. Controls and Service Components Accessible from the Left



SPECIFICATIONS

NOTE

- *Specifications in this publication may not match those of official certification in some markets due to timing of publishing, variance in testing methods, and/or vehicle differences. Customers seeking officially recognized regulatory specifications for their **H-D X440T** should refer to certification documents and/or contact their respective dealer or distributor.*
- *Hero MotoCorp reserves the right to change specifications, equipment or designs at any time without notice and without incurring any obligation.*

TYRES

MOUNT	SPECIFIED TYRE SIZE	PRESSURE (COLD 20°C)
Front	100/90-18 56 H TL	33 psi
Rear	140/70-17 66 H TL	33 psi

⚠ WARNING

Hero MotoCorp **recommends** the use of its **specified tyres**. **H-D X440T** is not designed for operation with non-specified tyres, including snow, moped and other special-use tyres. Use of non-specified tyres can adversely affect stability, handling or braking and lead to loss of vehicle control, which could result in death or serious injury.

WEIGHTS AND DIMENSIONS

Weights

ITEM	SPECIFICATION
Kerb weight	192±2 kg



Dimensions

ITEM	SPECIFICATION
Overall length	2156 mm
Overall width	818 mm
Overall height	1094 mm
Wheelbase	1418 mm
Saddle height	805 mm
Ground clearance	170 mm

CAPACITIES

ITEM	CAPACITY
Fuel tank	13.5 litres
Engine oil	2.6 litres at disassembly
	2.25 litres at draining

ENGINE AND TRANSMISSION

Engine Specifications

ITEM	SPECIFICATION
Maximum power	20.5 kW @ 6000 r/min
Maximum torque	38.5 N-m @ 4000 r/min (Road mode)
	33.35 N-m @ 5500 r/min (Rain mode)
Bore and stroke	79.6 x 88.4 mm
Compression ratio	9.65:1
Displacement	440 cc
Spark plug	Federal Mogul REK6YC
Spark plug gap	0.8-0.9 mm
Valve clearance (in cold condition)	Intake- 0.10 mm±0.02 mm
	Exhaust- 0.22 mm±0.02 mm
Idle speed	2000±200 r/min (cold condition)
	1300±100 r/min (hot condition)



Transmission Specifications

ITEM	SPECIFICATION
Primary reduction	2.308
Final reduction	2.60
Transmission	Manual 6 speed
Gear ratio, 1 st	2.833
2 nd	1.875
3 rd	1.4
4 th	1.136
5 th	0.958
6 th	0.818

CHASSIS AND SUSPENSION

ITEM	SPECIFICATION
Front suspension	Inverted Front Forks
Rear suspension	Gas charged twin shock swingarm mount
Caster angle	25.5°
Trail length	101 mm
Brakes	Front- Dia 320 mm
	Rear- Dia 240 mm

ELECTRICAL

ITEM	SPECIFICATION
Battery	*MF Battery 12 V-8 Ah/ETZ-9
Alternator	325 W @ 5000 r/min
Headlamp	LED
Position lamp	LED
Tail/Stop lamp	LED
Turn signal lamp	LED
Turn signal indicator (RH/LH)	LED x 2 nos.
Hi beam indicator	LED
ABS indicator	LED
Licence plate lamp	LED
Side stand indicator	LED
Starter magnetic switch	25A (Main fuse)
Fuse box	15A X 3 & 10A X 3 (Main fuse) 15A, 10A & 25A (Spare fuse)

***MF stands for Maintenance Free**



NOTES



REMOVING VEHICLE FROM STORAGE

1. Charge and install the battery. See battery maintenance [\(page 111\)](#).
2. Inspect spark plugs. See replacing spark plug [\(page 92\)](#).
3. Inspect air cleaner and replace if necessary. See inspecting air cleaner [\(page 97\)](#).
4. Inspect drive chain slackness [\(page 102\)](#).
5. Perform the items in the pre-ride checklist [\(page 25\)](#).

PRE-RIDE CHECKLIST

1. Check the amount of fuel in the tank. Add fuel if required. See filling the fuel tank [\(page 27\)](#).
2. Adjust mirrors to proper riding positions.
3. Check the engine oil level. See check engine oil level [\(page 93\)](#).

4. Check brake fluid level. See checking brake fluid level and changing brake fluid [\(page 106\)](#).
5. Inspect brake pads and discs for wear. See inspecting brake pads and discs [\(page 108\)](#).
6. Check the hand and foot controls to be sure they are operating properly. Operate the front and rear brakes, throttle, clutch and shifter. See operation [\(page 39\)](#).
7. Inspect brake lines for wear or damage.
8. Check steering for smoothness by turning the handlebar through the full operating range.

WARNING

Be sure tyres are properly inflated, balanced, undamaged, and have adequate tread. Inspect your tyres regularly and see an Authorized dealer for replacements. Riding with excessively worn, unbalanced, improperly inflated, overloaded or damaged tyres can lead to tyre failure and adversely affect stability and handling, which could result in death or serious injury



9. Check tyre condition, pressure and vehicle loading. Refer to checking tyre pressure and inspecting tyres **(page 31)** for correct tyre inflation pressure and vehicle weight allowances.
10. Check rear shock settings. Adjust if necessary. See adjusting shock absorbers **(page 36)**.
11. Check for any fuel, oil or hydraulic fluid leaks.
12. Check drive chain slackness **(page 102)**.
13. Check clutch lever free play **(page 100)**.

⚠ WARNING

Be sure headlamp, tail and stop lamp and turn signals are operating properly before riding. Poor visibility of rider to other motorists can result in death or serious injury.

14. Check all electrical equipment and switches including the stop lamp, turn signals and horn for proper operation.
15. Service your **H-D X440T** as necessary.

BREAK-IN RIDING RULES

The First 800 Kilometers

The sound design, quality materials, and workmanship that are built into your new Harley-Davidson X440T by Hero MotoCorp will give you optimum performance right from the start.

To allow your engine to wear-in its critical parts, we recommend that you observe the riding rules provided below for the first 800 km.

1. During the first 250 km of riding, keep the engine speed below 3000 rpm in any gear. Do not lug the engine by running or accelerating at very low rpm, or by running at high rpm longer than needed for shifting or passing.
2. Up to 800 km, vary the engine speed and avoid operating at any steady engine speed for long periods. Engine speed up to 3500 rpm in any gear is permissible.
3. Drive slowly and avoid fast starts at wide open throttle until the engine has warmed up.
4. Avoid lugging the engine by not running the engine at very low speeds in higher gears.
5. Avoid hard braking. Break-in new brakes with moderate use for the first 160 km.



FILLING THE FUEL TANK

WARNING

Use care when refueling. Pressurized air in fuel tank can force petrol to escape through filler tube. Petrol is extremely flammable and highly explosive, which could result in death or serious injury.

Removing Fuel Tank Cap

1. See Figure 6. To unlock fuel tank cap, lift the key hole cover (1).
2. Insert ignition key (2) turn it clockwise.
3. See Figure 7. Lift open the cap (3).

NOTICE

Do not spill fuel onto the vehicle while refueling. Immediately wipe up fuel spills on your H-D X440T. Fuel can cause damage to cosmetic surfaces.

4. Fill the tank. Use only recommended fuel. See fuel system information ([page 29](#)). Do not overfill the fuel tank. Insert the pump nozzle into the filler hole. There should be no fuel in filler neck (4). Fill the tank with fuel (5) as shown. See Figure 8.

A warm engine, the sun or extreme temperatures can cause the fuel to expand. Fuel can spill out of the tank and damage the finish. See safe operating rules ([page 3](#)).

Installing Fuel Filler Cap

WARNING

Do not use aftermarket fuel caps. Aftermarket fuel caps may fit improperly and leak, which could lead to death or serious injury. See an Authorized dealer for approved fuel caps.



1. To lock fuel tank cap, close the cap back on the opening and press gently.
2. The key springs back to the normal position and cap gets locked.
3. Remove the key and put back the keyhole cover.



Figure 6. Fuel Tank Cap

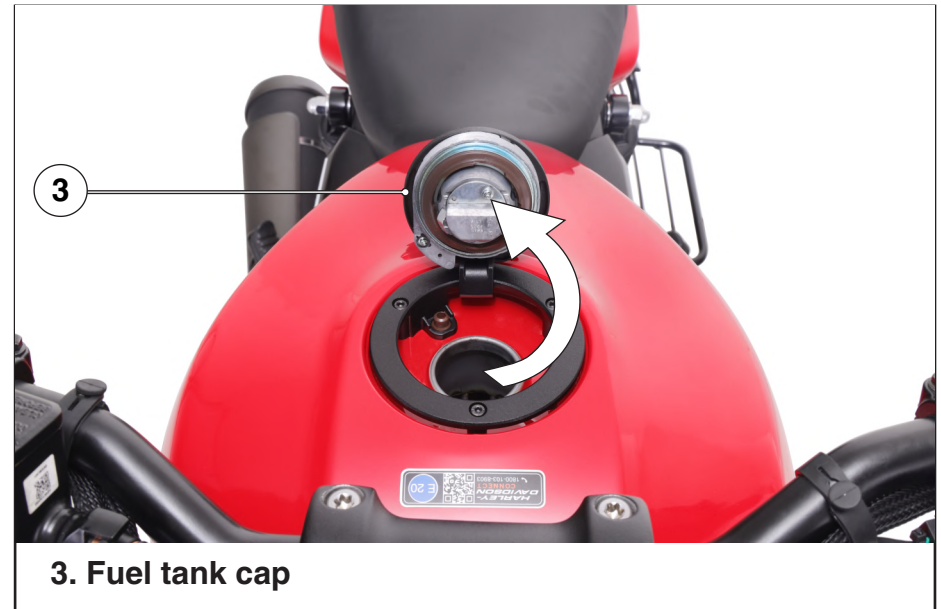

Figure 7. Fuel Tank Cap



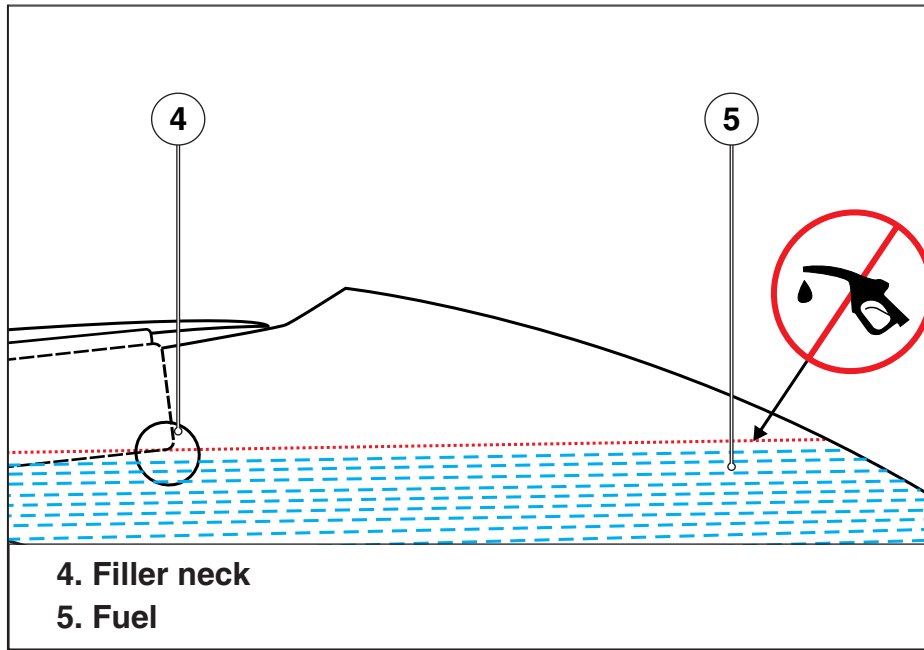



Figure 8. Fuel Level below Filler Neck

FUEL SYSTEM INFORMATION

Petrol containing alcohol

Fuel available at your location may contain ethanol. Ethanol is a form of alcohol and is generally mixed with petrol to reduce emissions.

 sticker on fuel tank indicates that the vehicle parts are compliant up to the blend of “20% ethanol with petrol”.

It is recommended not to use petrol containing more than 20% of ethanol to avoid any damage to engine and other parts of the vehicle.

If you observe any problem related to the operational performance of the vehicle, contact your Authorized dealer.

NOTICE

Please ensure that your H-D X440T is not used continuously when the low fuel indicator starts glowing. It will not only result in the vehicle running out of fuel, it may also cause serious damage to the fuel pump. Please ensure fuel is filled up as soon as the low fuel indicator starts glowing.

WARNING

- Petrol is highly flammable and explosive. You can be burned or seriously injured when handling fuel.
- Stop the engine and keep heat, sparks and flame away.
- Refuel only outdoors.
- Wipe off spills immediately.



CATALYTIC CONVERTER

Your H-D X440T is equipped with catalytic converters (page 117).

NOTICE

Do not operate catalytic converter-equipped vehicle with engine misfire. If you operate the vehicle under this condition, the exhaust will become abnormally hot, which can cause vehicle damage, including emission control loss. Do not snap the throttle in idle condition, this may lead to catcon damage.

ABS BRAKE SYSTEM IDENTIFICATION

Identification

See Figure 9 & 10. ABS can be identified by a wheel speed sensor on the right side of the front and rear wheel.

See Figure 11. ABS will also have an ABS module (HECU).



Figure 9. Front Wheel Speed Sensor (ABS identification)

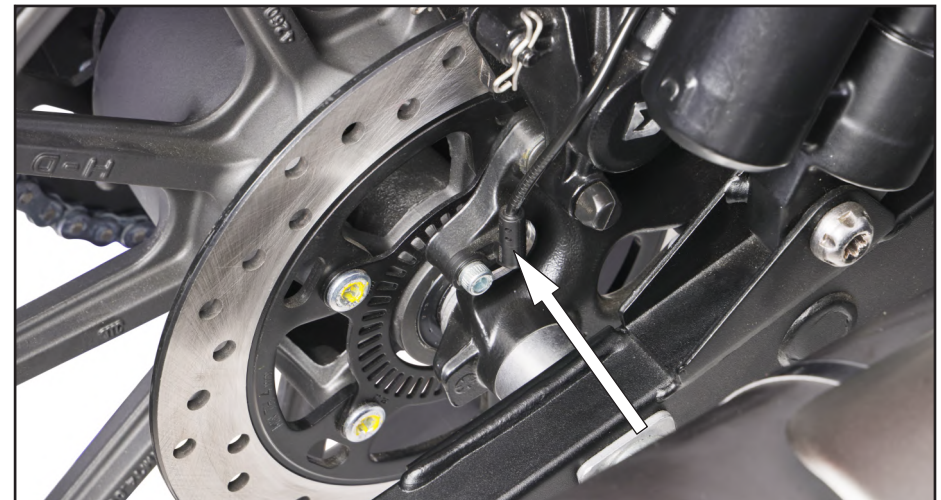

Figure 10. Rear Wheel Speed Sensor (ABS identification)





**Figure 11. ABS Module (HECU)
(located below Fuel tank)**

TYRES

To safely operate your **H-D X440T**, your tyres must be of the proper type and size, in good condition with adequate tread, and correctly inflated for the load you are carrying. The following pages give more detailed information on how and when to check the air pressure, how to inspect your tyres for damage, and what to do when your tyres need to be repaired or replaced.

⚠ WARNING

- Using tyres that are excessively worn or improperly inflated can cause a crash in which you can be seriously hurt or killed.
- Follow all instructions in this Owner's Manual regarding tyres inflation and maintenance.

Air pressure

Keeping your tyres properly inflated provides the best combination of handling, tread life and riding comfort.

Generally, under-inflated tyres wear unevenly, adversely affect handling and are more likely to fail from being overheated.

Under inflated tyres can also cause wheel damage in rocky terrain.

Over-inflated tyres make your **H-D X440T** ride harshly, are more prone to damage from road hazards, and wear unevenly.



We recommend that you visually check your tyres before every ride and use an air pressure gauge to measure air pressure at least once a month or any time you think the tyre pressure might be low. See Figure 12.



Figure 12. Air Pressure

For Tubeless Tyres

Tubeless tyres have some self-sealing ability if they are punctured. However, because leakage is often very slow, you should look closely for punctures whenever a tyre is not fully inflated. Always check air pressure when your tyres are "cold"-when the vehicle has been parked for at least three hours. If you check air pressure when your tyres are "warm"-when the vehicle has been ridden for even a few km-the readings will be higher than if the tyres were "cold".

32 Before Riding

This is normal, so do not let air out of the tyres to match the recommended cold air pressures given below. If you do, the tyres will be under-inflated.

The recommended "cold" tyre pressures are:

Tyres and Tyre Pressure

MOUNT	SPECIFIED TYRE SIZE	PRESSURE (COLD 20°C)
Front	100/90-18 56 H TL	33 psi
Rear	140/70-17 66 H TL	33 psi

NOTICE

Over inflation/Under inflation will affect the performance.

Inspection

Whenever you check the tyre pressure, you should also examine tyre treads & side walls for wear, damage & foreign objects.

Look for:

- Bumps or bulges in the side of the tyre or the tread. Replace the tyre if you find any bumps or bulges.
- Cuts, splits or cracks in the tyre. Replace the tyre if you can see fabric or cord.



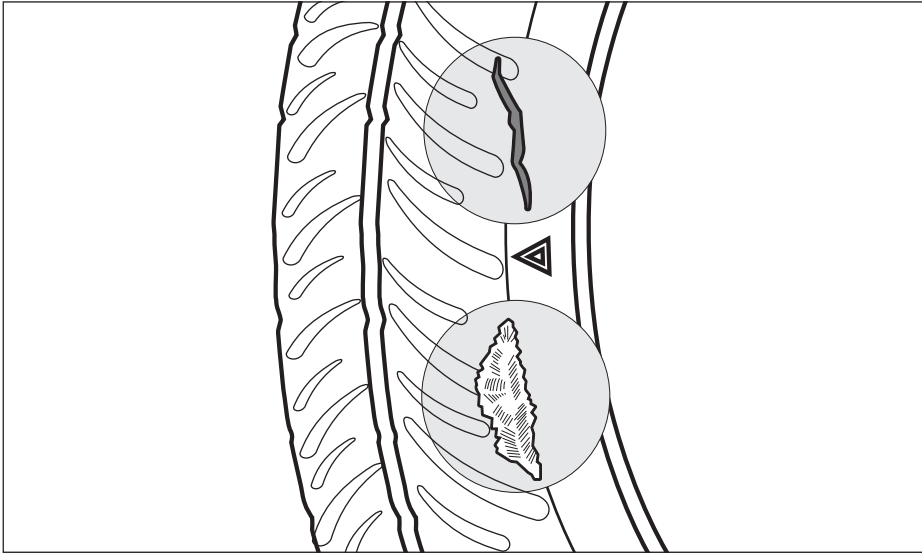

- Excessive tread wear.

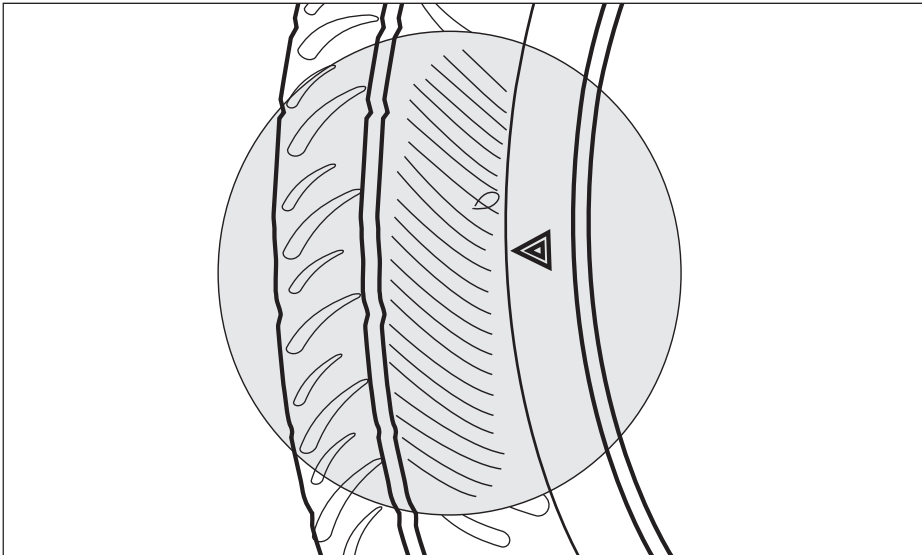

Unidirectional tyres

Whenever the tyre is removed and put back in case of puncture, ensure the arrow mark (2) on the tyre is in the same direction as that of forward rotation of wheel.

Replacing Tyres

⚠ WARNING

Tyres are a critical safety component. Contact an Authorized dealer for tyre repair or replacement. Improper tyre service can adversely affect stability and handling, which could result in death or serious injury.

⚠ WARNING

Hero MotoCorp recommends the use of its specified tyres. H-D X440T are not designed for operation with non-specified tyres, including snow, moped and other special-use tyres. Use of non-specified tyres can adversely affect stability, handling or braking and lead to loss of vehicle control, which could result in death or serious injury.



⚠ WARNING

Only install original equipment tyre valves and valve caps. A valve, or a valve and cap combination, that is too long or too heavy can strike adjacent components and damage the valve, causing rapid tyre deflation. Rapid tyre deflation can cause loss of vehicle control, which could result in death or serious injury.

⚠ WARNING

Replace punctured or damaged tyres. In some cases, small punctures in the tread area may be repaired from within the removed tyre by an Authorized dealer.

⚠ WARNING

Replace tyre immediately with a specified tyre when wear bars become visible or only 1/32 in (1 mm) tread depth remains. Riding with a worn tyre could result in death or serious injury.

New tyres are needed if any of the following conditions exist (refer to for the specified replacement tyres):

- Tread wear indicator become visible on the tread surfaces.
- Tyre cords or fabric become visible through cracked sidewalls, snags or deep cuts.
- Bumps, bulges or slits in the tyre.
- Punctures, cuts, or other damage to the tyre that cannot be repaired.

When installing tyres on rims, do not rely on tread design to determine direction of rotation. Always be sure the rotational arrows molded into the sidewalls point in the direction of rotation when the vehicle is moving forward.

NOTE

The imported tyre(s) if fitted without ISI mark; are in compliance of BIS standard and Central Motor Vehicle Rules 1989, as declared by the Tyre manufacturer.



ADJUSTING MIRRORS

⚠ WARNING

Objects in mirrors are closer than they appear. Use caution when judging distance of objects in mirrors. Failure to judge correct distances could result in death or serious injury.

Adjust mirrors so you can see a small portion of your shoulders in each mirror. This will help you establish the relative distance of vehicles to the rear of your H-D X440T.

OPERATING SIDE STAND

⚠ WARNING

Always park vehicle on a level, firm surface. An unbalanced vehicle can fall over, which could result in death or serious injury.

⚠ WARNING

The side stand locks when placed in the full forward (down) position with vehicle weight on it. If the side stand is not in the full forward (down) position with vehicle weight on it, the vehicle can fall over which could result in death or serious injury.

⚠ WARNING

Be sure side stand is fully retracted before riding. If side stand is not fully retracted, it can contact the road surface causing a loss of vehicle control, which could result in death or serious injury.

NOTE

When parking your H-D X440T on a grade, place the transmission in gear after turning off the engine.

See Figure 5. The side stand is located on the left side of the vehicle.

Side Stand Switch

The vehicle will start and run with the side stand down while the transmission is in neutral. If the side stand is down and the transmission in gear, engaging the clutch stalls the vehicle.





Raising the side stand or putting the transmission in neutral will permit the engine to run.

ADJUSTING SHOCK ABSORBERS

General

Rear shock absorber pre-load adjustment can be made in any position from 1st to 7th, according to the load/road conditions or owner's requirement.

Recommend Adjustment	
Riding Condition	Position
Solo rider 	2nd position
Rider + Pillion  (with or without luggage)	7th position (max preload)

- In direction A: Hard
- In direction B: Soft

WARNING

Adjust both shock absorbers equally. Improper adjustment can adversely affect stability and handling, which could result in death or serious injury.

NOTE

- *The total payload (total weight of rider, pillion & accessories etc.) on the vehicle should not exceed 150 kgs.*
- *Adjustment position should be set same on the left & right rear shock absorber.*
- *Do not adjust the positions from 1st to 7th or 7th to 1st directly.*

See Figure 13. To adjust the rear shock absorber (1), use the rear shock absorber adjustment tool [(Pin spanner) (2) with handle (3)] available in the tool kit.





- 1. Rear shock absorber
- 2. Pin spanner
- 3. Pin spanner handle
- (A) Hard
- (B) Soft

Figure 13. Shock Absorber Preload Adjustment



NOTES



CONTROLS, INSTRUMENTS AND SWITCHES

Clutch Hand Lever

WARNING

Do not position fingers between hand control lever and handlebar grip. Improper hand positioning can impair control lever operation and cause loss of vehicle control, which could result in death or serious injury.

See Figure 3. The clutch hand lever (1) is operated with the fingers of the left hand. See Riding ([page 81](#)).

Gear Shift Lever

See Figure 14. The gear shift lever is operated with the left foot. Neutral is found between first and second gear in the six speed shift pattern. See Riding ([page 81](#)).

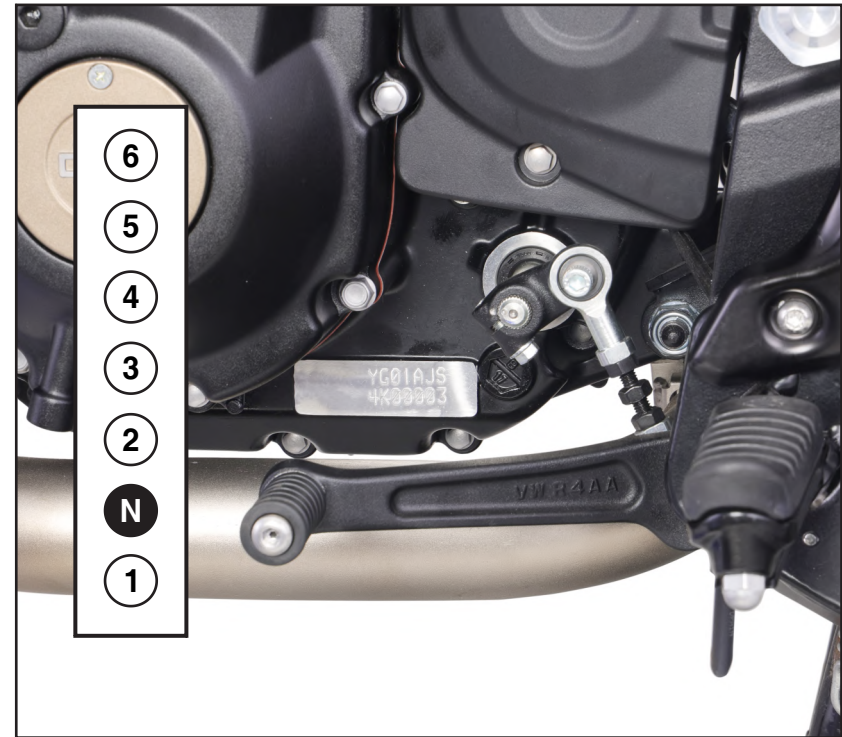

Figure 14. Shift Pattern and Shift Lever

Left-Hand Control Module

See Figure 3. Operate the switches on the left hand control module (2) with the thumb of the left hand. See Left Hand Control Switches ([page 68](#)).



Speedometer/Odometer

See Figure 3. The current road speed is displayed in the speedometer. The accumulated mileage and individual trip mileage is displayed in the odometer window in the face of the speedometer. See Instruments (page 42).

Right-Hand Control Module

See Figure 3. Operate the switches on the right hand control module with the thumb of the right hand. See Right Hand Control Switches (page 72).

Brakes

WARNING

Do not position fingers between hand control lever and handlebar grip. Improper hand positioning can impair control lever operation and cause loss of vehicle control, which could result in death or serious injury.

Front brake lever: See Figure 3. The front brake lever (12) controls the front brake. Operate hand lever with fingers of right hand.

Rear brake pedal: See Figure 5. The rear brake pedal (4) activates the rear wheel brake. Operate rear brake pedal with right foot.

40 Operation

WARNING

Do not apply brake strongly enough to lock the wheel. A locked wheel will skid and can cause loss of vehicle control, which could result in death or serious injury.

Apply brakes evenly to prevent wheels from locking up. A balance between rear and front brake is best.

Throttle Twist Grip

Accelerate: See Figure 3. Slowly twist throttle twist grip backward (toward rear of vehicle) to open the throttle.

Decelerate: Slowly twist throttle control grip forward (toward the front) to close the throttle.

Ignition Switch

NOTE

The front position lamp function in headlamp assembly and tail/stop lamp assembly will operate when ignition switch is “ON”.

See Figure 15. Unlock the ignition switch with the ignition key. Rotate the switch to the desired position.

- To start the engine, see Starting the Engine (page 76).



STEERING LOCK

NOTICE

Turn the ignition switch to the “OFF” position before locking the vehicle.

NOTICE

Protect your vehicle against theft. After parking your H-D X440T, lock the steering. Failure to lock your H-D X440T can result in theft and/or equipment damage.

See Figure 15. Park your **H-D X440T**. Use the steering lock to discourage theft or unauthorized use.

1. Turn the steering full left.
2. Insert the key into the switch.
3. Push the key in and turn to LOCK.
4. Remove the key.
5. To unlock steering, insert key, push and turn to OFF position. Remove key.

6. Check steering for proper operation by turning the handlebars through the full operating range.
Handlebars should turn smoothly without binding.

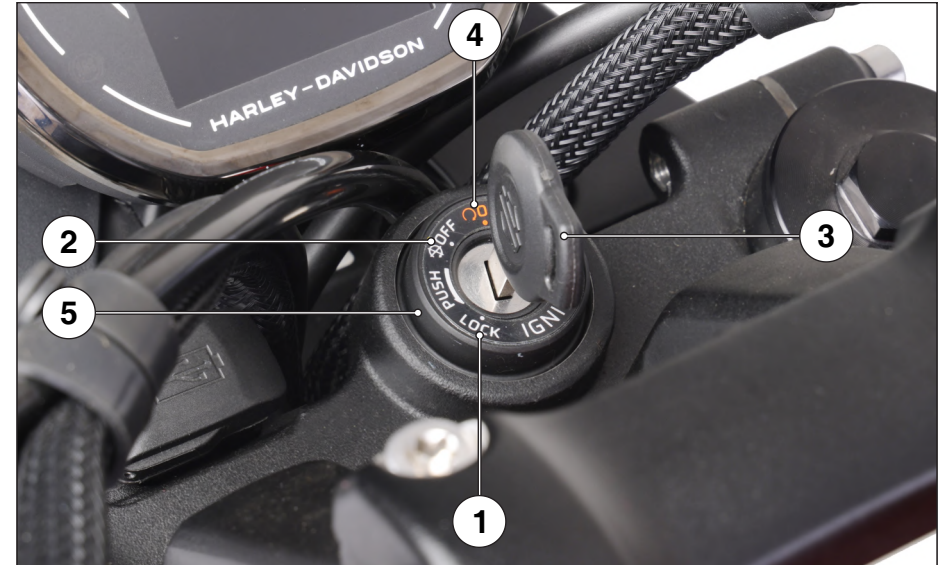





1. Steering lock position
2. “OFF” (⊗) position
3. Ignition key
4. Ignition “ON” (○) position
5. Ignition switch

Figure 15. Ignition and Steering Lock Switch



Ignition Switch and Steering Lock

SWITCH	NAME	FUNCTION
	IGNITION	Turns on ignition, lamps and accessories. The engine will start and run.
	LOCK	Steering can be locked.
	OFF	Engine cannot be started and no electrical system will be functional.
	PUSH	Push to lock the steering.

INSTRUMENTS

Speedometer

See Figure 16. The speedometer (1) indicates riding speed in kilometers per hour (km/h).

Odometer

The odometer (2) shows accumulated distance travelled.

Fuel gauge

See Figure 16. The fuel gauge (3) indicates approximate fuel available in the form of bar graph.

The bar graph will swing to maximum scale on the meter console once the ignition switch is turned "ON". If all the bar graph are displayed it means fuel quantity in the fuel tank is 13.5 litres.

42 Operation



1. Speedometer
2. Odometer
3. Fuel gauge
4. Gear indicator
5. Shift up indicator
6. Shift down indicator
7. Tachometer

Figure 16. Speedometer/Tachometer/
Gear & Shift Indication/Fuel Gauge/Odometer

Gear & Shift indication

See Figure 16. Indicates current gear position (4) of your **H-D X440T** in which it is running and assists the rider to shift gear for achieving optimum fuel efficiency and best ride experience based on your **H-D X440T** engine performance.



It displays following riding instructions :

- Shift up indicator (5): it recommends for shifting to high gear.
- Shift down indicator (6): it recommends for shifting to low gear.

NOTE

- Gear indicator displays “N” when your **H-D X440T** is in neutral.
- Gear indicator displays “-” when gear is stuck between 2 gears or when you change gears in vehicle static condition (vehicle is in main stand (optional) and ignition switch is in "ON" position).
- It is recommended to ride your **H-D X440T** as per road and traffic conditions.

Tachometer

See Figure 16. Shows engine revolution per minute. The tachometer (7) is displayed in the form of bar graph.

Malfunction indicator lamp (MIL)

See Figure 17. When the ignition switch is turned “ON” the malfunction indicator lamp (MIL) (1) glows continuously and then should go “OFF” once the engine is started. It indicates that vehicle is OK. If it glows continuously there is an abnormality in the vehicle, it is recommended to reduce the speed and drive to the Authorized dealer for check-up.

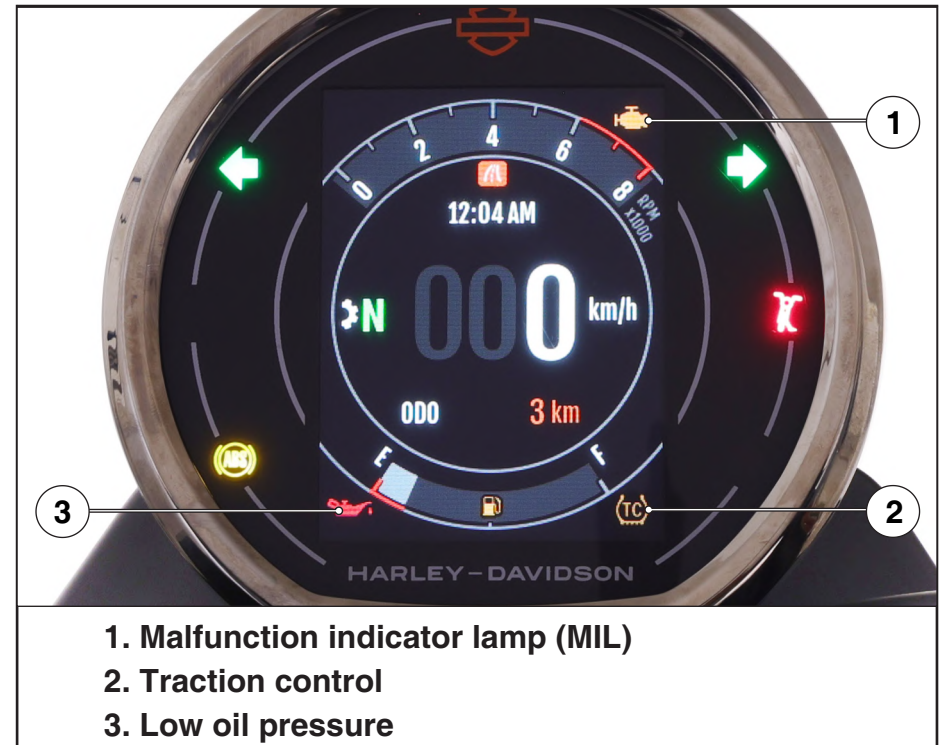

Figure 17. Malfunction indicator lamp (MIL)/
Traction control/Low oil pressure



Traction control indicator

Traction control indicator See Figure 17. When the ignition switch is turned “ON” [Start-kill switch should be at “ON” (ⓘ) position] the traction control indicator (2) (tc) will illuminate and remain illuminated until vehicle achieved the speed ≤ 5 km/hr.

The TCS indicator will turn “OFF” once the vehicle exceeds 5 km/h it indicates the traction control system is operational. The TCS indicator will blink rapidly when the traction control to manage the rear wheel slip during periods of hard acceleration or under wet or slippery road conditions.

At any point, while riding or in standstill condition, if TCS indicator (tc!) remain illuminated traction control system is not working and has a malfunction. Traction control may be disabled and the motorcycle may be operating as if traction control is turned off. It is recommended to reduce the speed, avoid excessive acceleration and drive to the nearest Authorized dealer for check-up.

NOTE

If the traction control is switched “OFF” by the rider the “TC Off (tc) or not available” tell-tale indicator will be illuminated.

NOTE

The traction control malfunction indicator (tc!) may be illuminated in some cases, such as:

- *When the electric starter (ⓘ) of integrated start-kill switch is pressed but the engine did not start.*
- *TCS may not functioned if there is any malfunction with ABS.*

In such cases it is recommended to turn the ignition switch off and start after 10 seconds. If the malfunction indicator still remains illuminated, there may be a fault with the system. It is recommended to reduce the speed, avoid excessive acceleration and drive to the nearest Authorized dealer for check-up.

Low oil pressure indicator

See Figure 17. When the ignition switch is turned “ON” the low oil pressure indicator glows continuously and then should go “OFF” once the engine is started. It indicates that engine oil pressure in the system is OK. If it glows continuously there is an abnormality in the lubrication system engine oil pressure, it is recommended to reduce the speed and drive to the Authorized dealer for check-up.



Service due

See Figure 18. Indicates how many kilometres are left before the next service is due (1). Press the down button (2) on the left handlebar until the next service distance is displayed.



**Figure 18. Service due/
Service reminder indicator/Date**

Service reminder indicator

See Figure 18. The service reminder indicator (3) is to indicate the user to bring the vehicle to an Authorized dealer for service. The indicator shall start blinking when the vehicle covers kilometers as specified in the maintenance schedule. The indicator will keep on blinking throughout the kilometer interval for a particular service and will stay "ON" thereafter.

Date

See Figure 18. Displays the day, month and year (4).

For date setting refer to the procedure below:

- Turn the ignition switch "ON" (⊙).
- Date will be adjusted in configurable menu.
- See Figure 19. To open the bike setting (1) on the meter console press and hold the set button (2).
- See Figure 19. Navigate to display setting (3) on the meter console by pressing the down button (4) and press the set button (2) to open the display setting.
- See Figure 19. In display setting navigate to date and time setting (5) by pressing the down button (4) and press the set button (2) to open the date and time setting.
- See Figure 19. In date and time setting navigate to date setting (6) on the meter console by pressing the down button (4) and press the set button (2) to open the date setting.



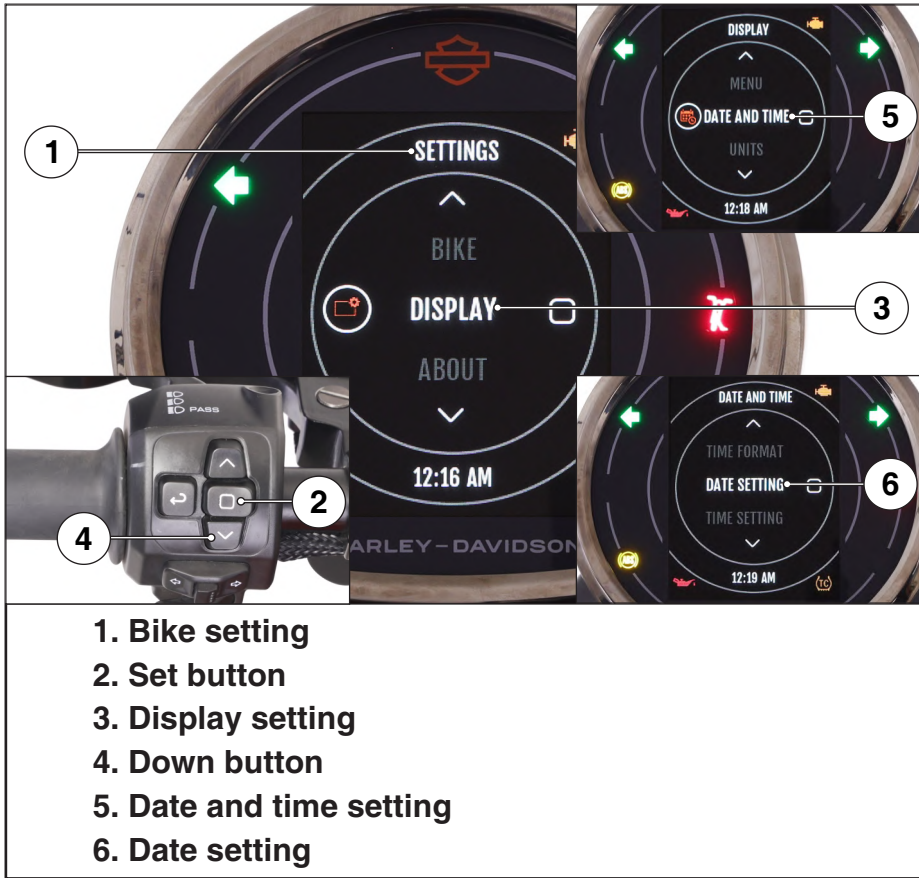

Figure 19. Setting

- See Figure 20. To set the desired day, press up/down button (7) until the desired day is displayed.
- See Figure 20. To set month, press the set button (8) to switch from day to month display. Now press the press up/down button (7) until the desired month is displayed.

46 Operation

- See Figure 20. To set year, press the set button (8) to switch from month to year display. Now press the press up/down button (7) until the desired year is displayed.
- See Figure 20. To set the date (9) press and hold the set button (8).

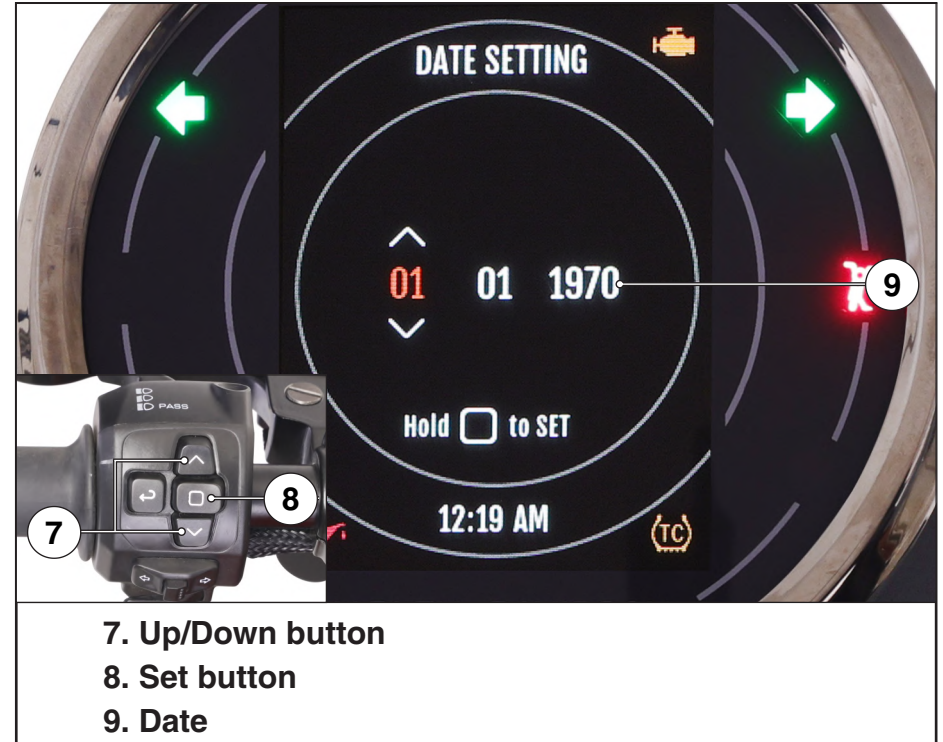

Figure 20. Date setting

⚠ CAUTION

Interacting with the meter console screen while the vehicle is in motion may cause accidents and injury .



Clock

See Figure 21. Indicates hours & minutes.

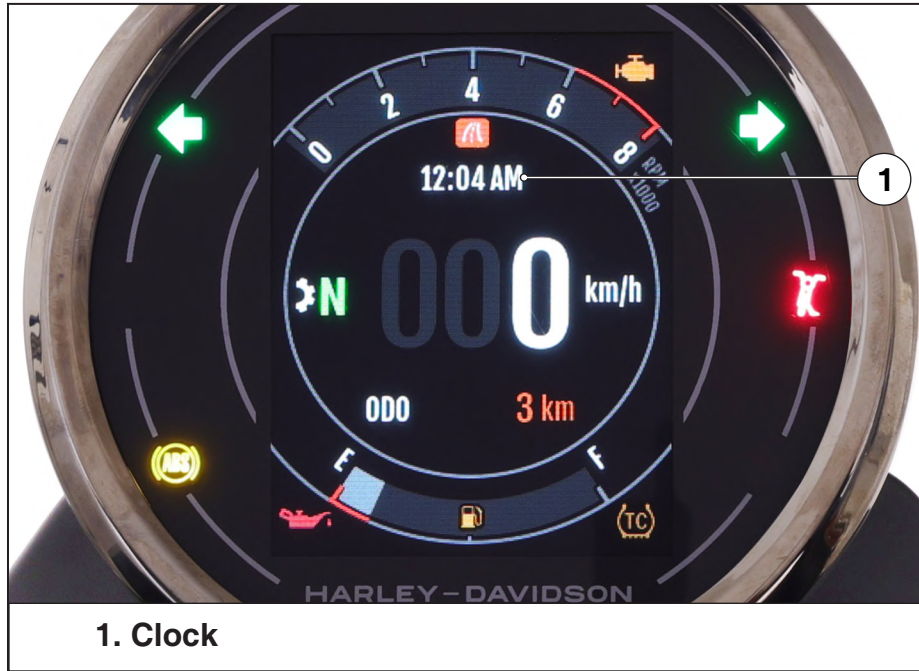

Figure 21. Clock

For clock setting refer to the procedure below:

- Turn the ignition switch "ON" (Ⓞ).
- Clock will be adjusted in configurable menu.
- See Figure 22. To open the bike setting (2) on the meter console press and hold the set button (3).
- See Figure 22. Navigate to display setting (4) on the meter console by pressing the down button (5) and press the set button (3) to open the display setting.

- See Figure 22. In display setting navigate to date and time setting (6) by pressing the down button (5) and press the set button (3) to open the date and time setting.

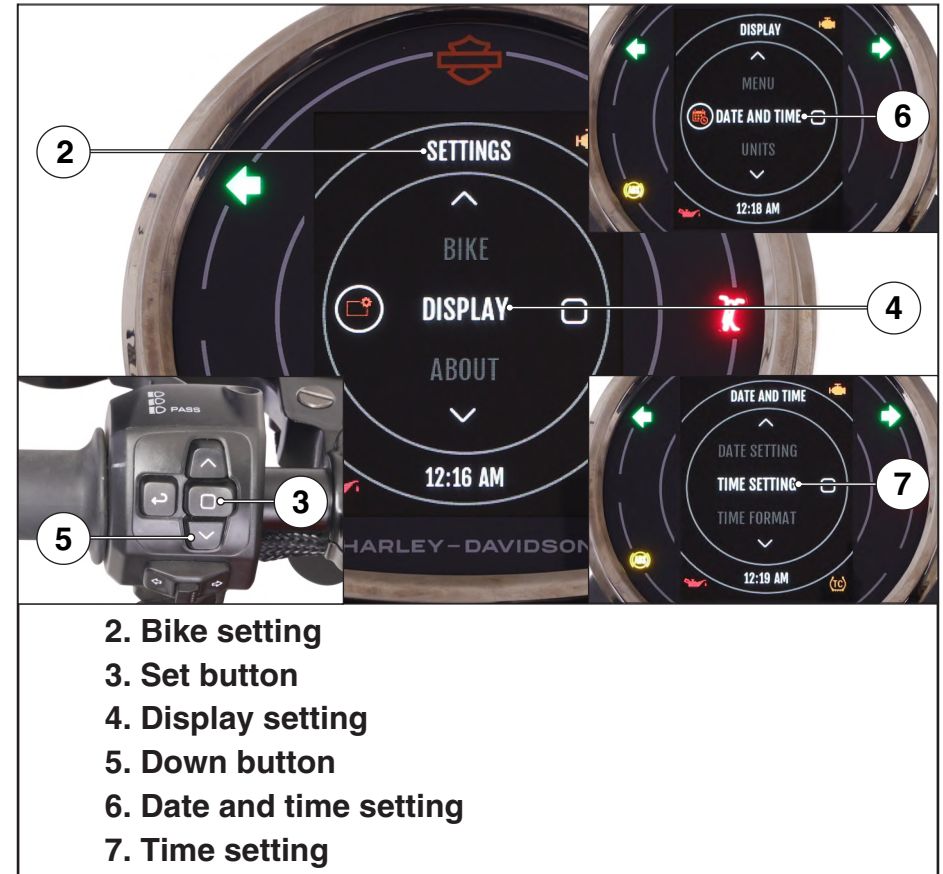

Figure 22. Setting



- See Figure 22. In date and time setting navigate to time setting (7) on the meter console by pressing the down button (5) and press the set button (3) to open the time setting.
- See Figure 23. To set the hour, press up/down button (8) until the desired hour is displayed.
 - The time is advanced by 1 hour each time the up/down button (8) is pressed.
 - The time advances fast when the up/down button (8) is pressed and held.
- See Figure 23. To set minute, press the set button (9) to switch from hour to minute display. Now press the up/down button (8) until the desired minute is displayed.
 - The time is advanced by 1 minute each time the up/down button (8) is pressed.
 - The time advances fast when the up/down button (8) is pressed and held.
- See Figure 23. To change AM-PM, press the set button (9) to switch from minute to AM-PM display. Now press the press up/down button (8) to select the AM-PM.
- See Figure 23. To set the clock (10) press and hold the set button (9).



Figure 23. Time setting

NOTE

The clock will reset to “1:00” if the battery is disconnected.



Tripmeter

The tripmeter shows distance travelled since trip meter was reset last time. See Figure 24. There are two tripmeters, "Trip A" and "Trip B".

See Figure 25. Short press the set button (1) on the handlebar to view "Trip A" display.

Press the down button (2) to select "Trip B".

"Trip A" and "Trip B" can be displayed upto "999.9" km.

If the tripmeter exceeds "999.9" km it will return to "0.0" km automatically.

See Figure 25. Press the set button (1) to view the following tripmeter parameters:

- **Distance (3):** distance covered in a trip.
- **Trip time (4):** time taken to complete a trip.
- **Avg speed (5):** average speed at which vehicle completes a trip
- **Avg fuel consumption (FE) (6):** average fuel consumption at which vehicle covers the trip distance.

To view the above parameters press up/down button (2).

When tripmeter sub menu is selected, long press (more than 2 seconds) the set button (1) to reset tripmeter to zero.



Figure 24. Tripmeter A & B



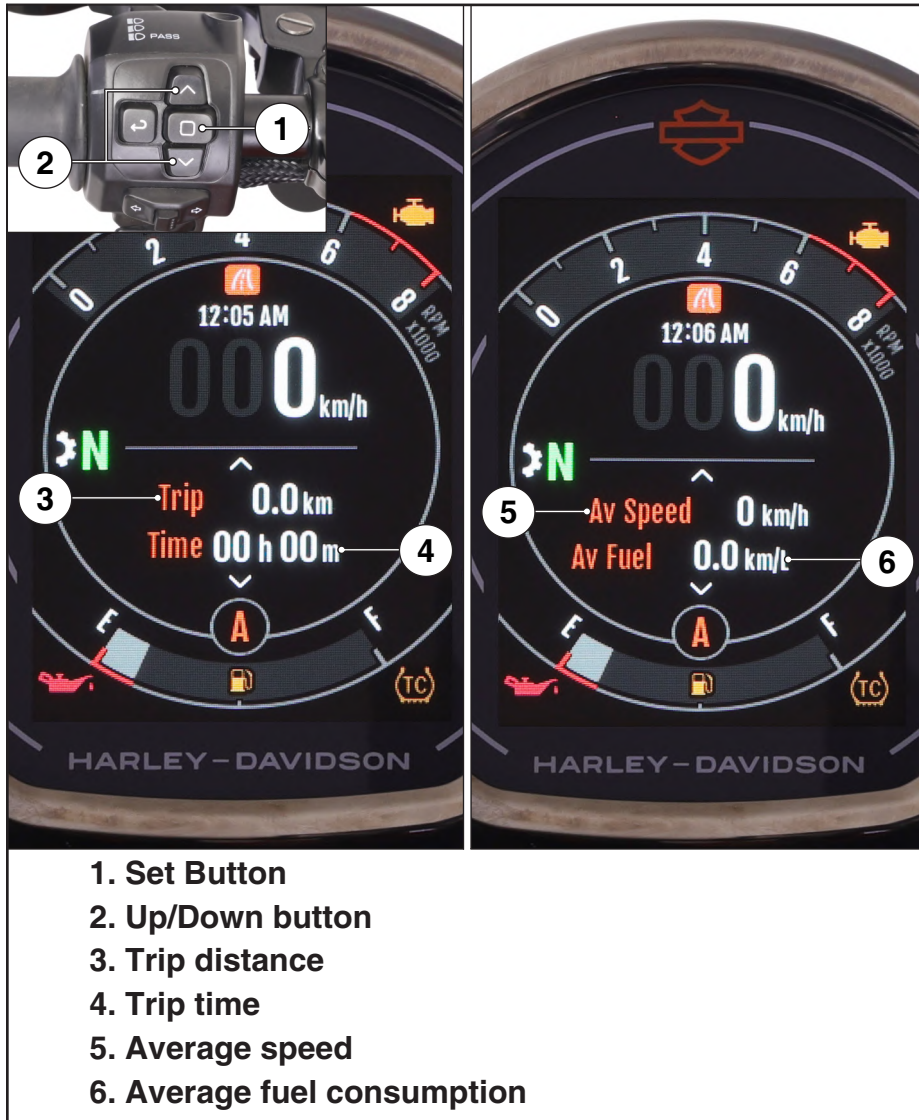

Figure 25. Tripmeter display

Real time mileage indicator (RTMI)

See Figure 26. The real time mileage indicator (RTMI) (1) shows the current mileage of the vehicle in km/litre and is refreshed after every 3 seconds. Press the set button (2) repeatedly press the down button (3) until the RTMI is displayed.

When the ignition switch is turned “ON” (Ⓞ) position, the real time mileage indicator will temporarily show the digit “---.- km/l” which indicates that all the digital LCD segments are working. The display range is from (0 to 120 km/litre).

The fuel consumption shall be displayed when the speed of the vehicle is more than 5 ± 2 km/hr. If the speed is less than 5 ± 2 km/hr “---.-” shall be displayed.

The RTMI shows a minimum value of 0.0 km/litre and maximum value of 120 km/litre. During coasting with throttle fully closed, the fuel consumption is very minimal and hence the display can go up to 120 km/litre.

Distance to empty (DTE)

See Figure 26. Distance to empty indicator (DTE) (1) indicates distance (in km) that can be travelled on the remaining fuel in the tank.



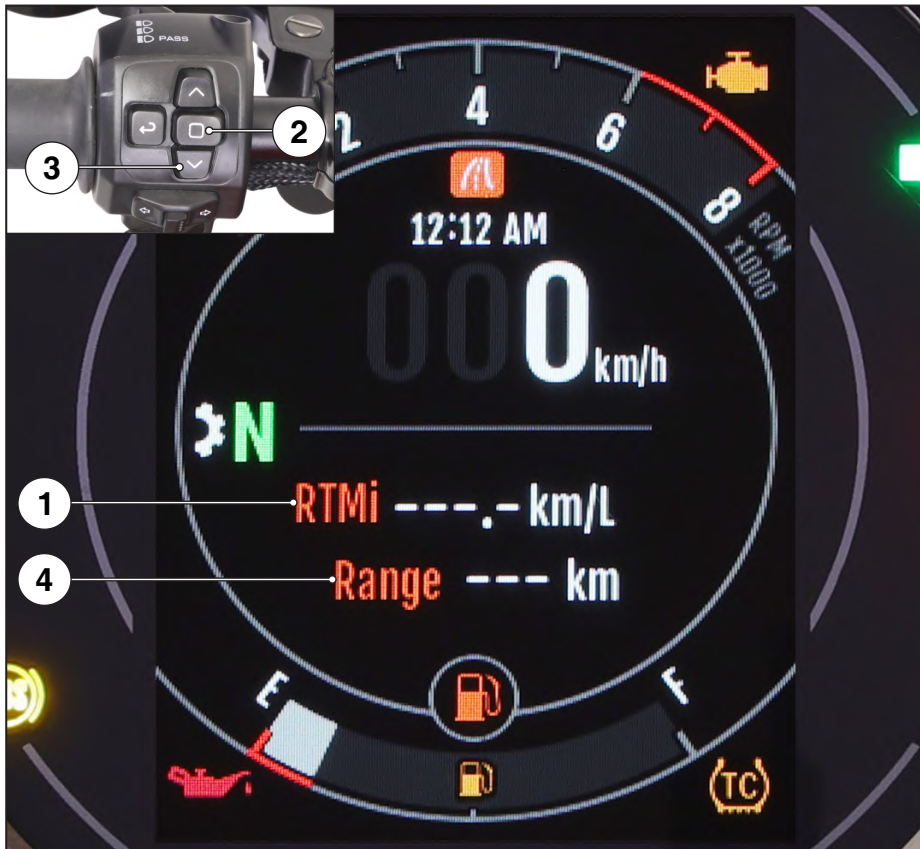

1. Real time mileage indicator (RTMI)
2. Set button
3. Down button
4. Distance to empty

Figure 26. RTMI/DTE

Navigation

See Figure 27. The navigation screen (1) will display turn by turn navigation instruction to the rider once cluster receives the navigation data from the App. Press the set button (2) repeatedly press the down button (3) until the navigation is displayed.



1. Navigation
2. Set button
3. Down button

Figure 27. Navigation



Music

See Figure 28. The music screen (1) will display music information like track name, artist/genre/album, duration level, play/pause and track change of the music which plays from rider smartphone once cluster is connected with bluetooth via App. Press the set button (2) repeatedly press the down button (3) until the music screen is displayed.

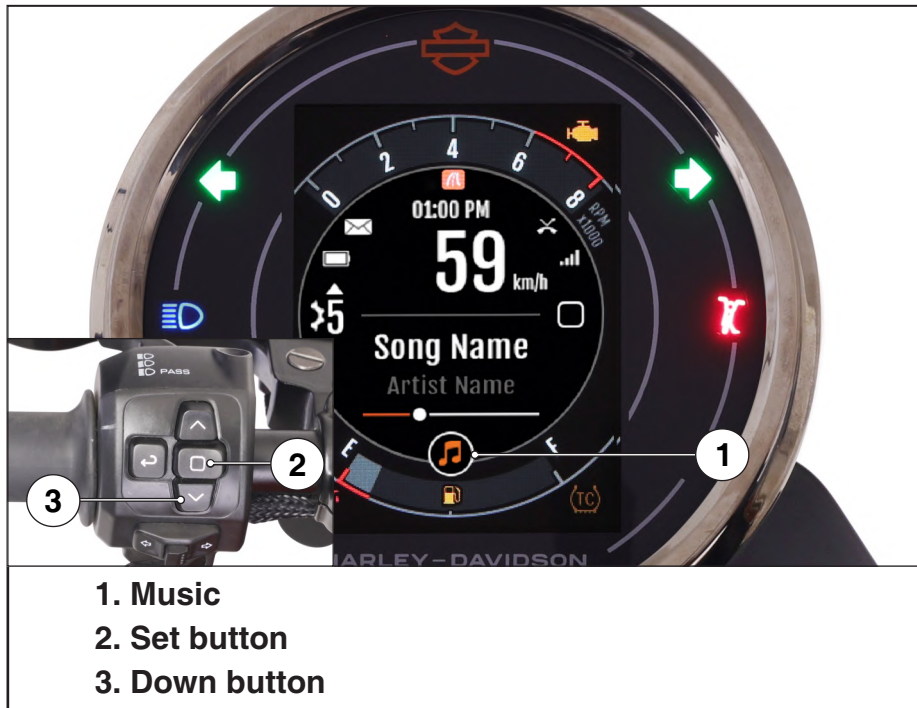

Figure 28. Music control

Setting

See Figure 29. To open the setting (1) on the meter console press and hold the set button (2) on the handlebar.

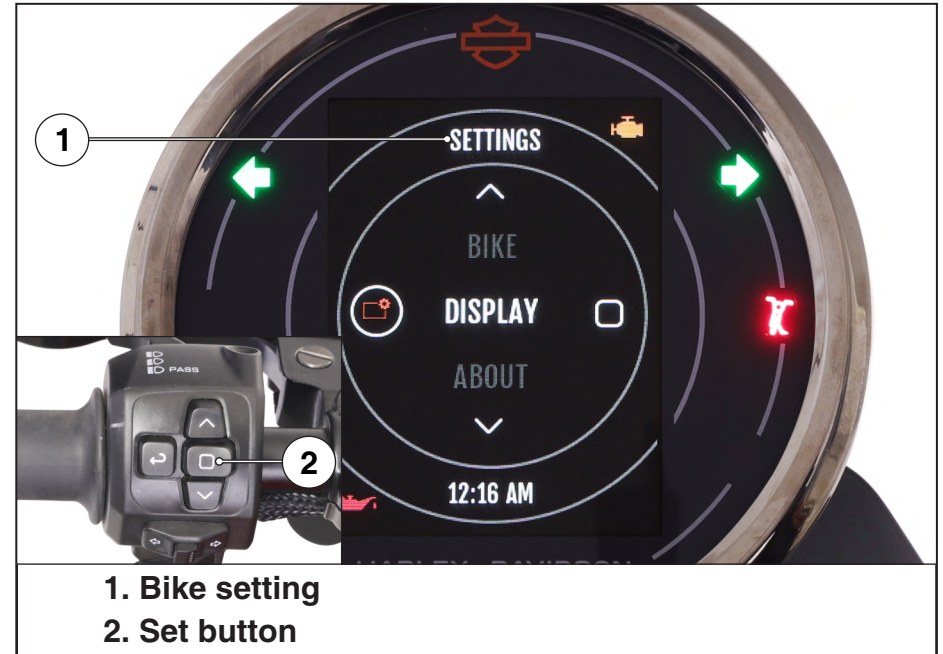

Figure 29. Setting

There are different settings which can be configured by the user according to the preference

See Figure 30. User can navigate through the settings by using up button (1) or down button (2).

See Figure 30. To select the setting press set button (3) and to come out from the setting press back button (4) on the handlebar.





Figure 30. Home screen navigator control

Meter console display the following features:

1. Bike

a. Trip A & B

See Figure 31. User can view trip A & B distance, trip time, average speed and average fuel consumption (FE). User can reset the tripmeter by press and hold the set button on the handlebar.

b. Battery

See Figure 31. User can view the vehicle's battery voltage.

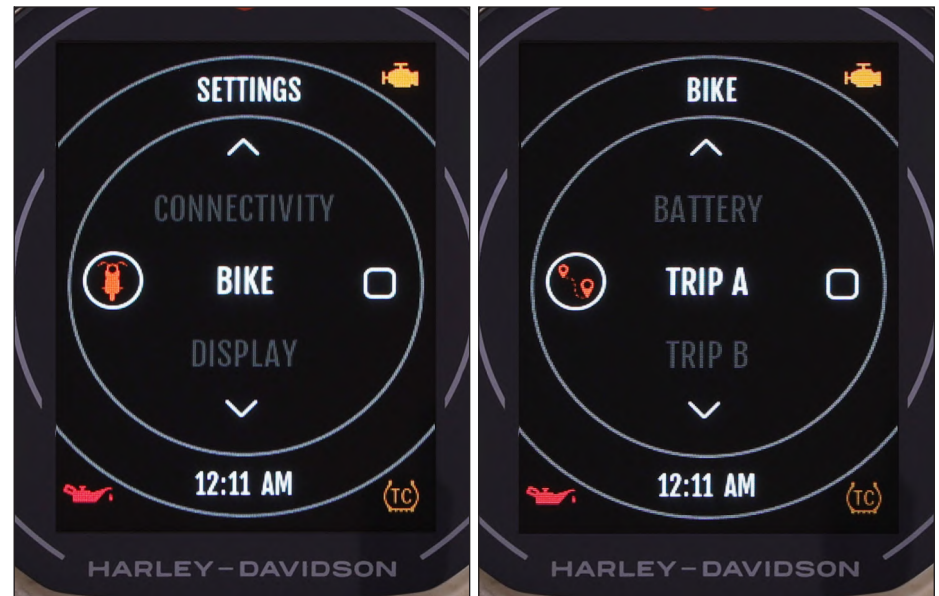

Figure 31. Bike settings



c. Ride mode

User can select the ride mode from the meter console setting (page 52).

See Figure 32. The ride mode displays the currently selected ride mode. The selected ride mode can be changed using the up/down button (1) and to select the desired mode press the set button (2) on the left handle control switches.

- **Road:** Delivers balanced performance with an intuitive blend of technology for daily use, with Anti-lock Braking System (ABS) and Traction Control System (TCS) intervention that offers peace of mind.
- **Rain:** This mode offers restrained acceleration and limited engine braking with higher levels of ABS and traction control intervention to give the rider greater confidence when riding in the rain or when traction is otherwise limited. The Rain Mode is also an appropriate setting for riders to build confidence as they become familiar with the vehicle.

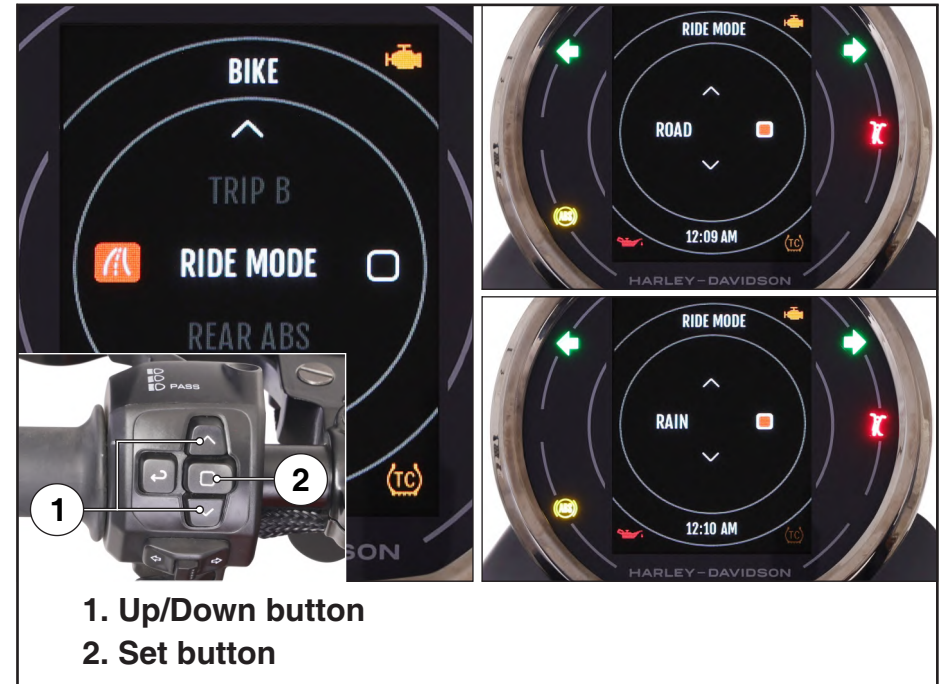

Figure 32. Ride Mode settings

Ride Mode Selection (Running Condition)

See Figure 33. User can change the ride mode while vehicle is running by press and hold the down button (1) for more than 3 seconds and press the down button (1) and to select the desired mode press the set button (2) on the left handle control switches.



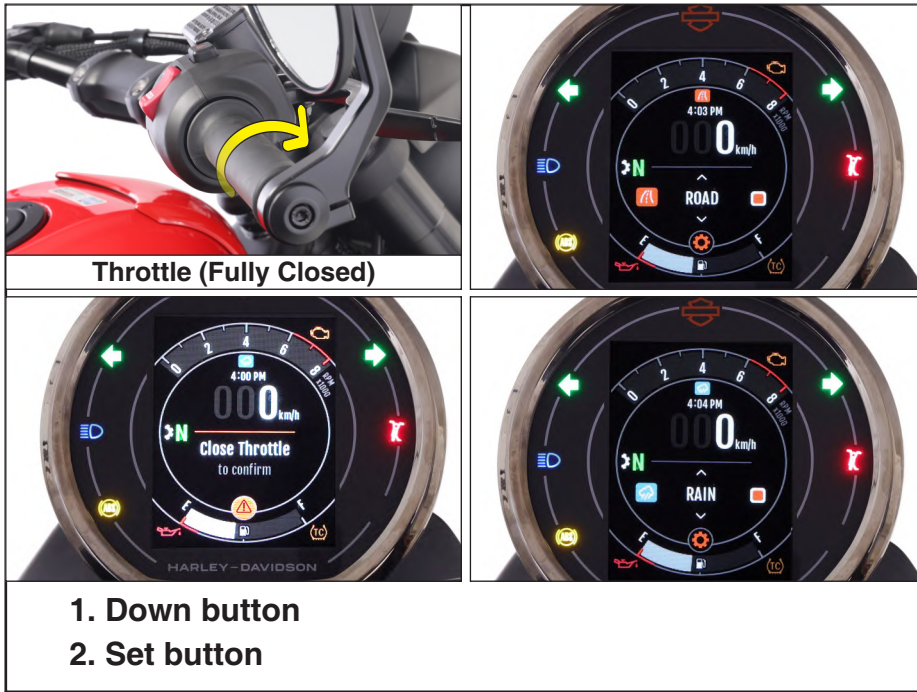

Figure 33. Ride Mode settings

NOTE

The throttle must be completely released (fully closed) when switching Ride Modes while riding.

d. Rear ABS

See Figure 34. Vehicle is equipped with a Rear ABS switchable function:

User can select the rear ABS switchable function from the meter console setting ([page 52](#)).

Rear ABS switchable function (1) can be set to “ON” or “OFF” using the set button (2) on the left handlebar.

- When we switch off Rear ABS, ABS light will blink continuously at a low frequency even after >5km/hr indicating to the rider that the Rear ABS is deactivated.
- Switchable rear ABS to temporarily disable the rear ABS for more control desired by skilled riders.
- Lets riders use techniques like controlled rear-wheel slides or steering by locking the rear wheel on loose surfaces, which can be beneficial for maneuvering in off-road environments.



Figure 34. Rear ABS setting

NOTE

Rear ABS is not switchable in rain mode to ensure rider safety



e. Traction control

See Figure 35. Vehicle is equipped with a switchable Traction Control function:

User can select the traction control switchable function from the meter console setting (page 52).

User can select traction control switchable function (1) “ON” or “OFF” by pressing the set button (2) on the left handle control switches.

- Designed to prevent the rear wheel of a vehicle from losing traction or spinning during acceleration.
- Efficient transfer of engine power to the road surface by managing wheel slip.
- Enhanced vehicle stability especially on slippery surfaces like wet pavement, gravel, or painted lines, and during aggressive acceleration.
- TC Switchable option brings flexibility to the vehicle in various riding conditions.



Figure 35. Traction control setting

NOTE

Traction control not switchable in rain mode to ensure rider safety.



2. Display

See Figure 36. To customize the meter console user can select from different display settings.

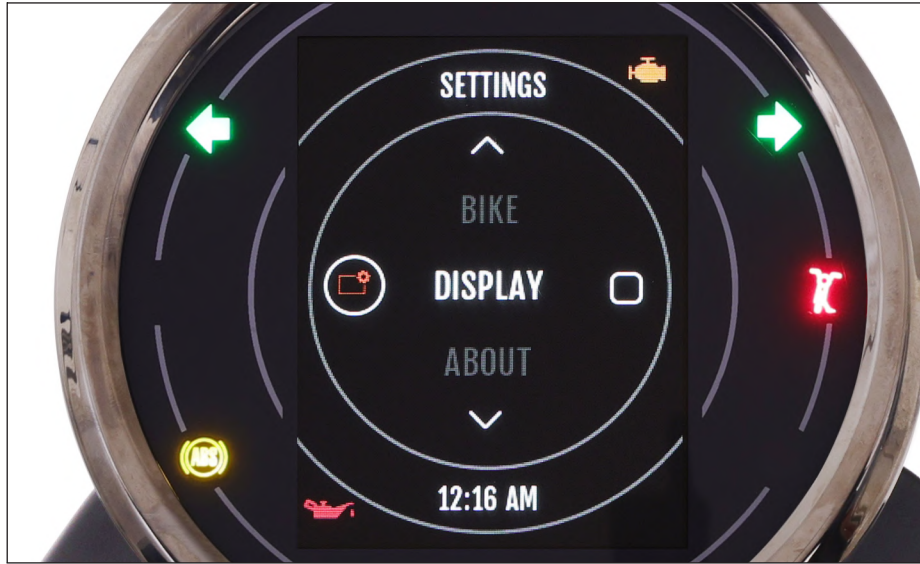

Figure 36. Display settings

a. Appearance

See Figure 37. Appearance feature allows the user to adjust the brightness level of the TFT display and DRL. Select the display mode of cluster from the option of day and night or auto. When day mode is selected headlamp will be “OFF”, when night mode is selected headlamp will be “ON” or when auto mode is selected TFT backlight brightness is adjusted automatically and headlamp will be “ON”/“OFF” as per the lighting condition around the vehicle.

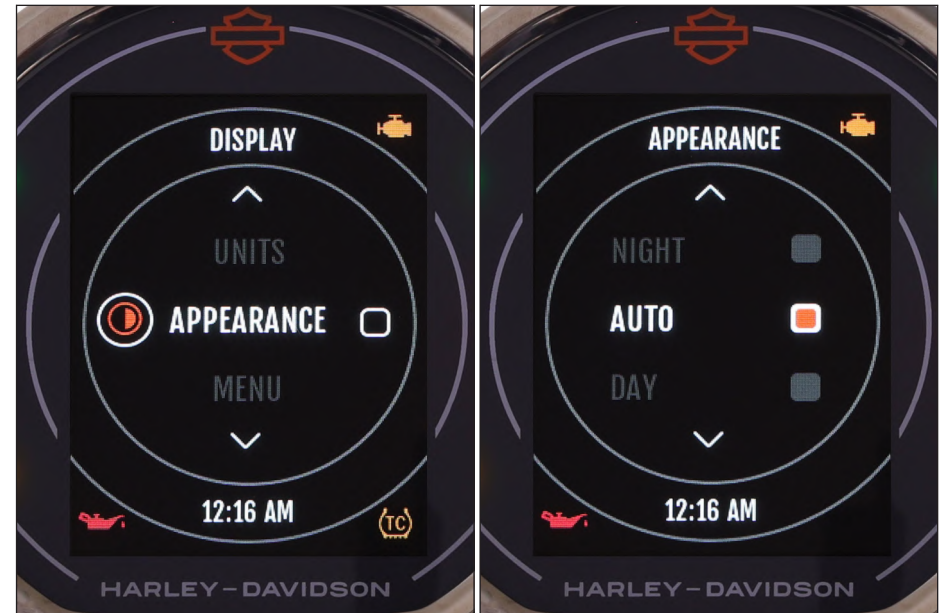

Figure 37. Appearance settings

b. Menu

See Figure 38. User can select from different options which will be displayed on meter console menu screen. Below are the following options which can be displayed on the menu screen:

- Volume
- Trip B
- Fuel
- Navigation
- General information
- Music





Figure 38. Menu settings

c. Date and time

- **Time format-** See Figure 39. User can change the time format between 24 hour or 12 hour.
- **Date setting-** See Figure 39. User can set the date [\(page 45\)](#).
- **Time setting-** See Figure 39. User can set the time [\(page 46\)](#).

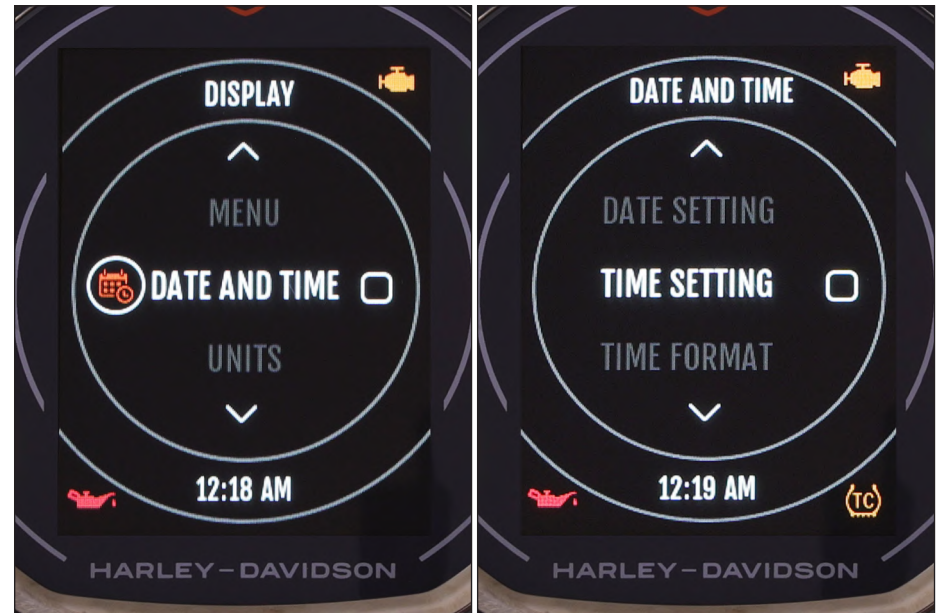

Figure 39. Date and time settings



d. Units

- **Distance**-See Figure 40. Any distance which is displays on the meter console are shown in kilometers.
- **Fuel consumption**-See Figure 40. User can change the fuel consumption unit between “km/L” to “L/100km”.

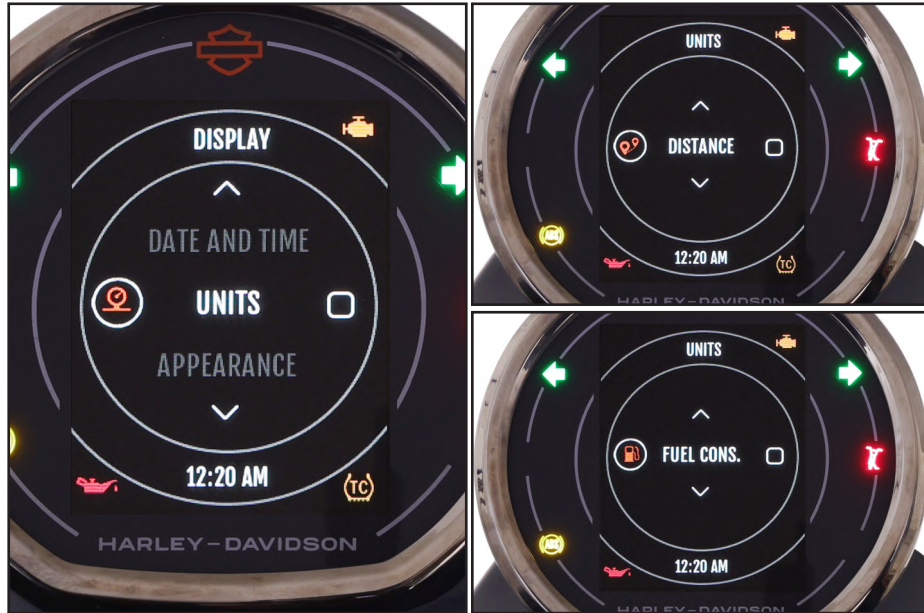

Figure 40. Units settings

3. About

- a. **Rider info**-See Figure 41. User can view the rider information which are stored through the App.
- b. **Software version**-See Figure 41. User can view the meter console updated software version.
- c. **Disclaimer**-See Figure 41. User can view the disclaimer about the meter console.



Figure 41. About settings



4. Connectivity

See Figure 42. User can connect meter console with bluetooth.

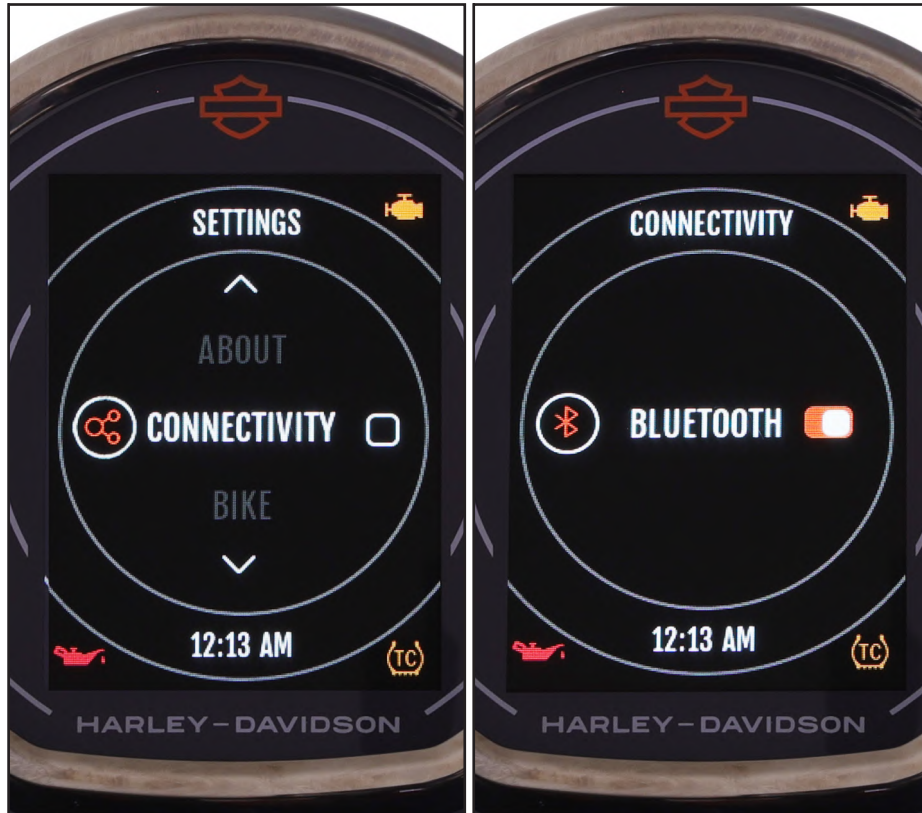

Figure 42. About settings

INDICATORS

Turn signal indicators

See Figure 43. Turn signal indicators (1) flash when turn signal switch is operated.



1. Turn signal indicators
2. High beam indicators
3. Anti-lock braking system (ABS) indicator
4. Side stand indicators

Figure 43. Indicators



High beam indicator

See Figure 43. High beam indicator (2) glows when headlamp is on high beam.

Anti-lock braking system (ABS) indicator

See Figure 43. The ABS indicator (3) on meter console come "ON" for 1.8 seconds when the ignition switch is turned "ON" (⊙) & then keeps blinking until the vehicle attains a speed of 5 km/h.

When the system functions normally indicator goes "OFF" (⊙) once vehicle speed exceeds 5 km/h.

At any point if ABS indicator remains "ON" then ABS is not working, but the brakes still work normally. Reduce your **H-D X440T** speed and visit your Authorized dealer.

Side stand indicator

See Figure 44. Side stand indicator (4) glows when the vehicle is parked on the side stand.

For the safety of the customer a side stand indicator is provided.

See Figure 44. A side stand switch (1) is provided in the side stand, when the side stand is down (ignition switch "ON" (⊙), the switch enables the side stand indicator lamp to glow on the meter console.

- See Figure 44. Check the side stand for proper function and the spring (2) for damage or loss of tension and the side stand assembly for free movement.
- Check whether the side stand indicator glows when the side stand is down.

- While the vehicle is removed from side stand, the side stand indicator should not glow.
- If the side stand indicator does not operate as described in above steps, please visit your Authorized dealer.

⚠ CAUTION

Ensure that adequate care should be taken while cleaning the side stand switch.

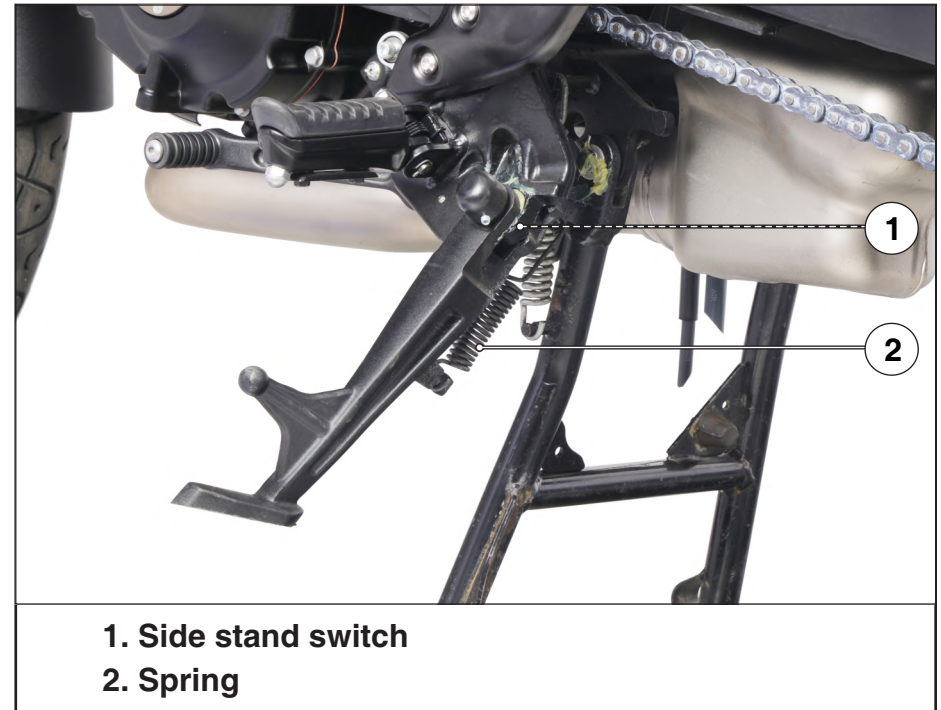

Figure 44. Side stand switch



Your **H-D X440T** is equipped with “Side stand engine kill” feature for safety purpose.

This feature has the following functions:

- It prevents starting the engine when transmission is in gear (irrespective of the clutch lever operation) and the side stand is down.
- It stops the running engine when transmission is in gear (irrespective of the clutch lever operation) and side the stand is moved down.

 **WARNING**

“Side stand engine kill” system is not affected by clutch lever operation.

To inspect the functionality of this feature, park the vehicle on its main stand (optional) and check all the conditions described in the inspection flow diagram:



INSPECTION FLOW DIAGRAM

1. Turn the ignition switch to "ON" (⊙) position and press the electric starter switch (with transmission in neutral and side stand down).

Does engine start?

NO

Visit Authorized dealer

YES

2. Then shift the transmission to gear (with engine running and irrespective of clutch lever operation).

Does engine stop?

NO

Visit Authorized dealer

YES

3. Now press the electric starter switch (After engine has stopped).

Does engine start?

YES

Visit Authorized dealer

NO

SYSTEM IS OK

If your **H-D X440T** doesn't operate as described in the above flow diagram, please visit your Authorized dealer.

WARNING

Regularly inspect the functionality of "Side stand engine kill" feature and in case of any malfunction visit an Authorized dealer.



H-D CONNECT – APP OVERVIEW

For accessing the bluetooth related features and for seamless connectivity between customer & the vehicle, a dedicated HD-Application (App) has been developed.

This App can be downloaded from Google Play Store (for android) or App Store (for iOS).

Below are the steps to Login to App & Homepage:

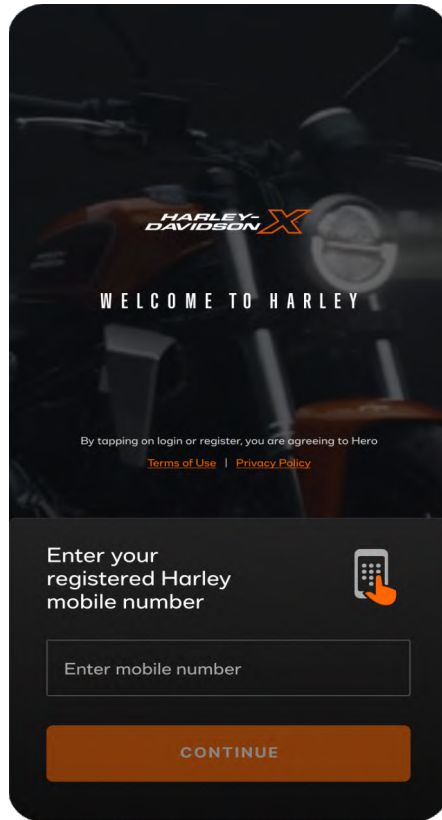

- Sign-in page appears once user opens the app after installation
- Login using registered mobile no.

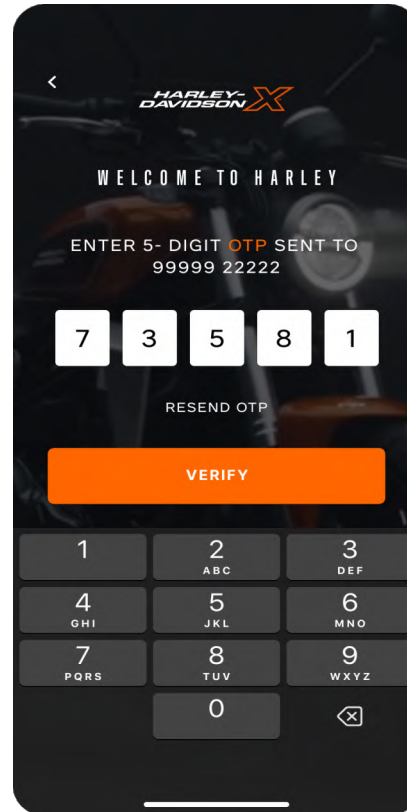

- OTP will be sent to mobile number entered.
- Verify OTP.



All models associated with entered mobile number will appear in App.

64 Operation



Bluetooth Activation

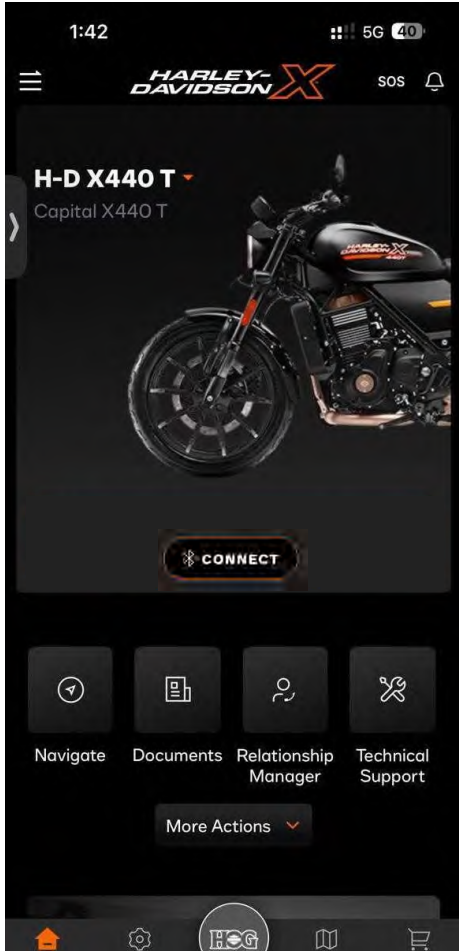

Click on the “Connect”

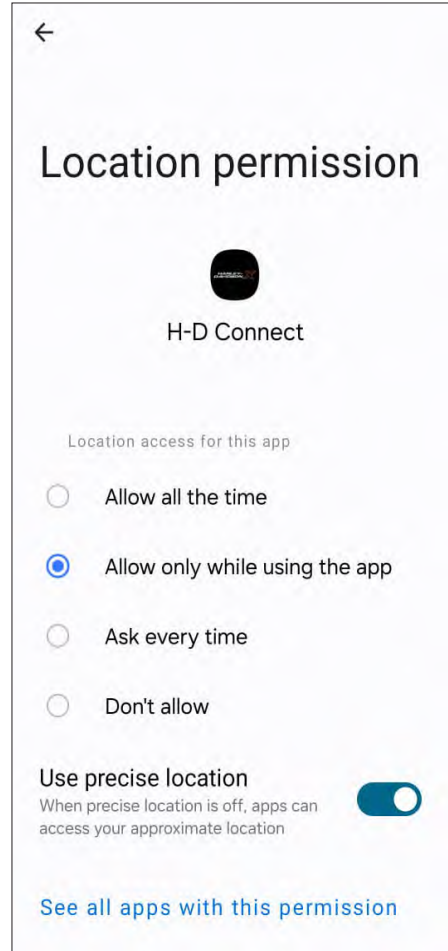

For first time pairing,
application ask for
permissions

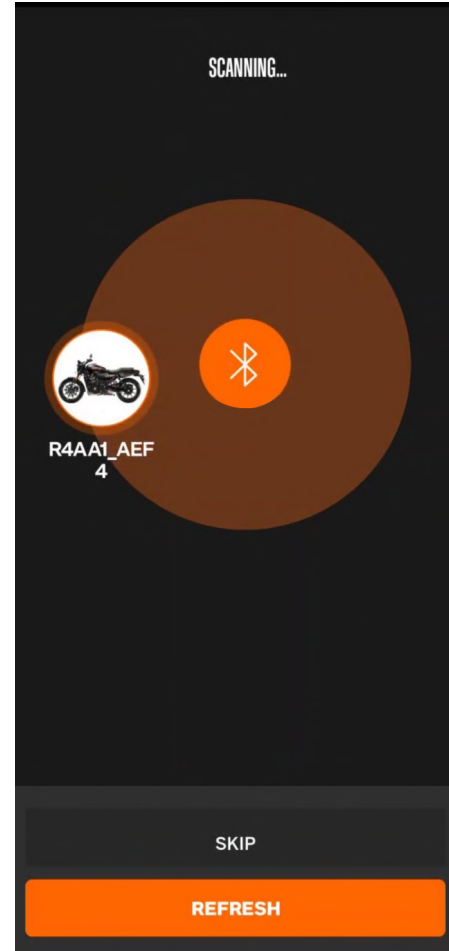

Application searches for
compatible nearby devices.
Select the device

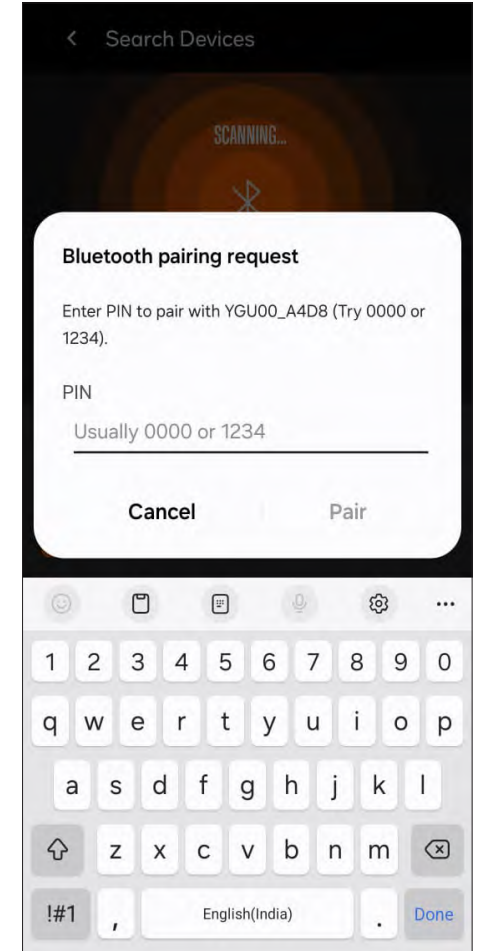

Meter console will display
paring pin
Enter the pin in application
screen and select “Pair”

65 Operation



1. Call Alert

When smartphone is paired with App then it will show all the incoming calls alerts on the meter console. It will display the name of the caller if it is stored in your compatible smartphone. For example: If caller's number is stored in your compatible smartphone by name of Vijay, then your meter console will display "Vijay".

If the number is not saved in user device by name, then it will display caller number.

If user device is an iOS, then it will display "unknown".

Call can be accept/reject using the set/back button. See Figure 30.



Call reject

Call accept

Operation 66

2. SMS & Missed Call Alert

When smartphone is paired with App then user will get all SMS Alert (Android) & Missed Call Alert on the meter console.



SMS alert

Missed call alert



3. Phone Battery Status & Phone Network Strength

When smartphone is paired with App then it will display phone battery status and phone network strength of user smartphone on the meter console.



4. Do not disturb (DND) mode

When smartphone is paired with App then user can switch "ON" the DND mode (android) in which user smartphone will be on vibrate mode and if you receive any call and SMS will be trigger and sent to the person who is calling stating "I'm riding bike, Please call me later".

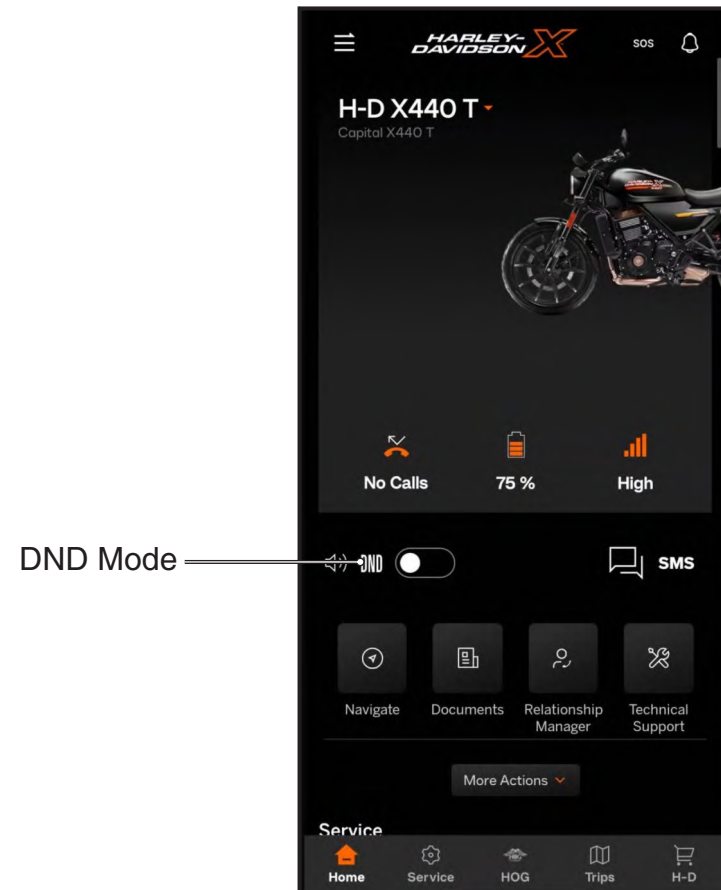

LEFT HANDLEBAR CONTROL SWITCHES

Turn signal lamp switch (↔)

See Figure 45. Shift the turn signal switch (1) sideways for right/left indications and leave it to come back to its normal position on its own.

IMPORTANT : To switch “OFF” the turn signal after completing the turn, gently push the switch inside.

Horn switch (📢)

See Figure 45. Press the switch to operate the horn (2).



Figure 45. Left handlebar controls

Home screen navigator control

See Figure 45. The home screen navigator control (3) is used to operate the following functions of the meter console:

- Up button—Scroll the meter console from the bottom to the top.
- Down button—Scroll the meter console from the top to the bottom.
- Back button—Press the back button to go back to the previous menu.
- Set button—Press to confirm selection.

⚠ WARNING

- It is recommended to use home screen navigator control when the vehicle is in stand still condition.
- Home screen navigator control assists you to control the meter console home screens, don't be distracted while driving.



Headlamp dimmer/Pass switch

Headlamp is equipped with a day time running lamp (DRL) to enhance the day light time visibility of the vehicle to other road users.



Figure 46 Left handlebar controls

See Figure 46. Headlamp dimmer/pass switch (2) has three positions. The three positions of headlamp dimmer/pass switch “”, “” and “ PASS” function differently based on day, night and auto mode as follows:

1. See Figure 47. When appearance is set to day mode (5). For details on appearance setting to day mode (page 57).

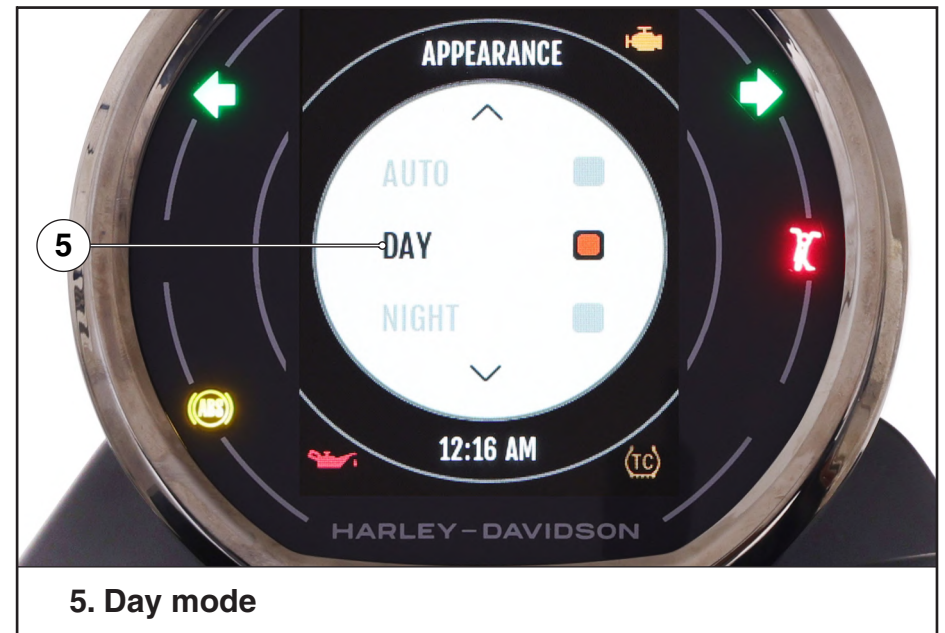



Figure 47. Appearance settings





When the ignition switch is turned “ON”, the position lamp will illuminate.

See Figure 46. Once the engine is turned “ON” and the headlamp dimmer/pass switch is set to “” (a) position, the DRL (1) will illuminate.

- DRL will be “ON”.
- High beam will be “OFF”.
- Low beam will be “OFF”.



See Figure 46. In engine running condition, when the headlamp dimmer/pass switch is set to “” (b) position, the DRL (1) will illuminate.

- DRL will be “ON”.
- High beam will be “OFF”.
- Low beam will be “OFF”.

PASS

See Figure 46. In engine running condition, when headlamp dimmer/pass switch “ PASS”, (c) position is pressed:

- High beam (4) will be “ON” till the time it is pressed.
- Low beam (3) will be “ON” till the time it is pressed.
- DRL (1) will be “ON”.

Operation 70

2. See Figure 48. When appearance is set to night mode (6). For details on appearance setting to night mode refer to [\(page 57\)](#).



6. Night mode

Figure 48. Appearance settings



See Figure 46. In engine running condition, when headlamp dimmer/pass switch is set to “” (a) position, low beam (3) and position lamp (1) will be “ON”.





See Figure 46. In engine running condition, when headlamp dimmer/pass switch is set to “” (b) position. High beam (4), low beam (3) and position lamp (1) will be “ON”.

PASS

See Figure 46. In engine running condition, when headlamp dimmer/pass switch “ PASS”, (c) position is pressed:

- High beam (4) will be “ON” till the time it is pressed.
- Low beam (3) will be “ON”.
- Position lamp (1) will be “ON”.

3. See Figure 49. When appearance is set to auto mode (7). For details on appearance setting to auto mode (page 57).

Once the appearance is in auto mode, headlamp illuminates as per the lighting condition around the vehicle.

WARNING

It is recommended to use the dimmer/pass switch positions “”, “”, “ PASS” and day/auto/night modes as per the visibility, road and traffic conditions.

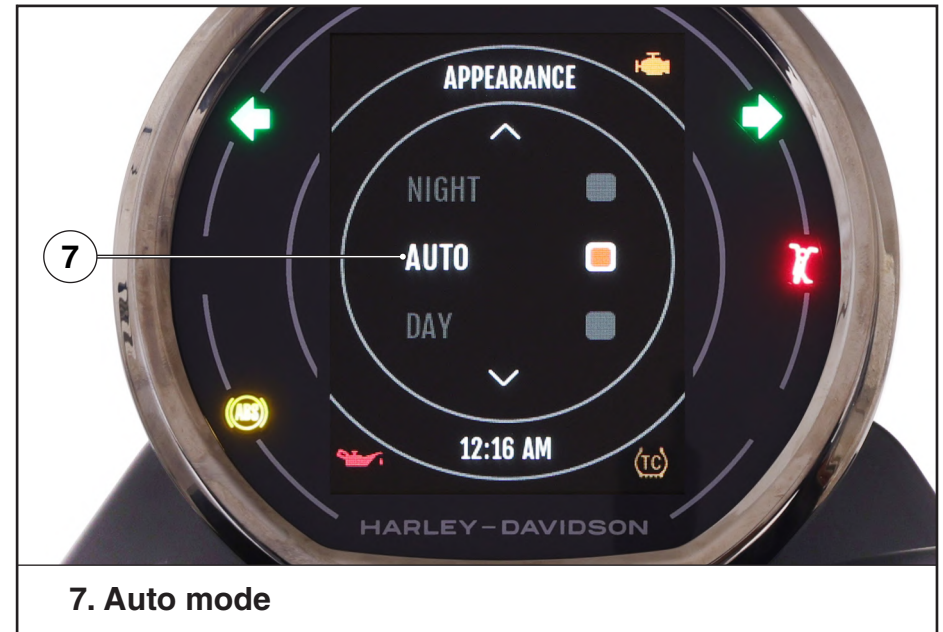

Figure 49. Appearance settings

Clutch switch

See Figure 50. There is a clutch switch (1) provided for the safety of the rider. The vehicle cannot be started by electric starter switch until the clutch lever is operated when the vehicle is engaged in gear.





1. Clutch switch

Figure 50. Clutch switch

RIGHT HANDLEBAR CONTROL SWITCHES

Integrated start-kill switch

(a) Electric starter operation (⊕)

See Figure 51. Press the electric starter (⊕) (1) of integrated start-kill switch (2) downwards to start the vehicle. Ensure the electric starter operation is done when the vehicle transmission is in neutral. If the vehicle is engaged in gear, press the clutch lever before electric starter (⊕) operation. Release switch after the engine has started.

Operation 72

⚠ CAUTION

Never hold electric starter (⊕) of integrated start-kill switch continuously for more than 5 seconds as continuous cranking of engine will discharge the battery.

(b) Engine stop switch operation

See Figure 51. For engine stop operation (3) integrated start-kill switch (1) has two positions. In “ON” (⊙) position, engine will operate and in “OFF” (⊗) position, engine will not operate. The prime function of this switch is to stop the engine during emergency (vehicle tip over, throttle cable stuck, etc.). The switch should normally remain in “ON” (⊙) position. During emergency, put the switch to “OFF” (⊗) position.

⚠ WARNING

While riding the vehicle in normal condition, do not press the “Integrated start-kill switch to “OFF” (⊗) position to avoid any damage (wheel locking leading to accident, part damage, battery discharge, etc.).



Hazard switch (⚠)

See Figure 51. Press the hazard switch (4) in ignition "ON" condition whenever your **H-D X440T** becomes a temporary hazard for other road users and it is necessary to park the vehicle due to breakdown or other unavoidable problems.

Upon pressing the hazard switch, all turn signal lamps start flashing simultaneously to warn other road users behind you of a hazard or obstruction ahead.

To turn "OFF" the indicator lamps in hazard switch "ON" condition, press the hazard switch again.

NOTE

*Use the hazard lights only when your **H-D X440T** becomes a temporary hazard for other road users.*

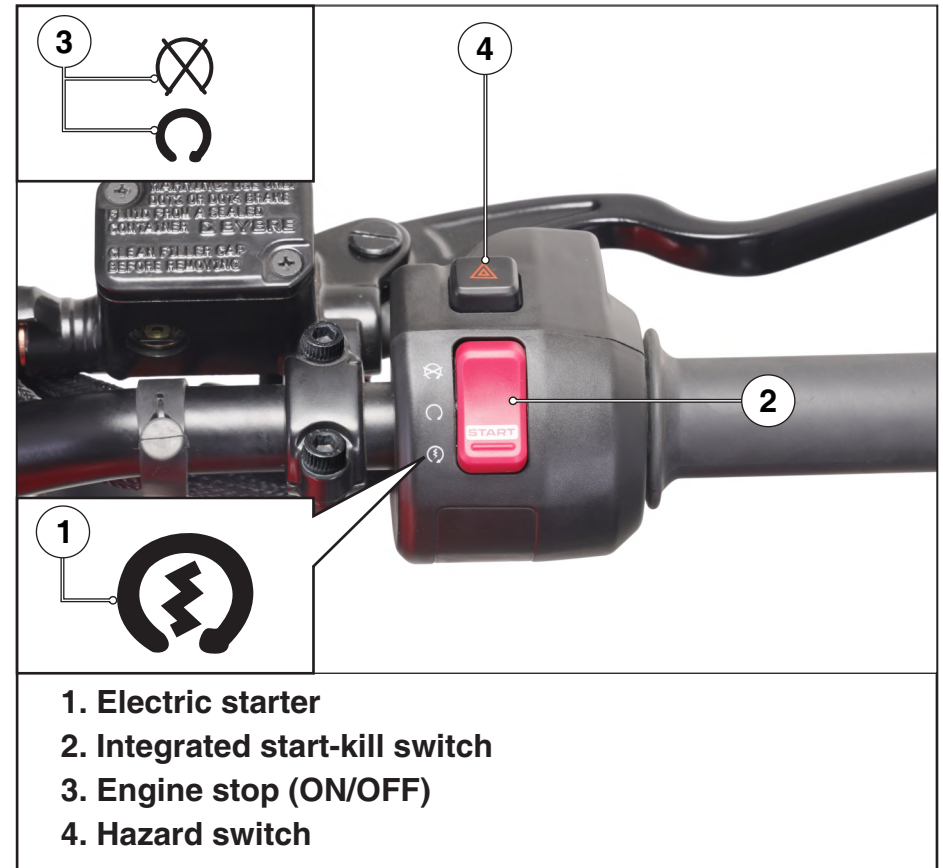

Figure 51. Right handlebar controls



USB CHARGER

See Figure 52. A USB charger (1) with a cap (2) located on the charger are located near the handlebar to charge your mobile phone safely while riding.

Use of non-standard USB cable may cause damage to the mobile phones.

To connect a mobile phone to the charger, first open the cap from the USB charger and then plug in the charger cable to it. Hero MotoCorp will not be responsible for damages caused due to use of non-standard USB cable.

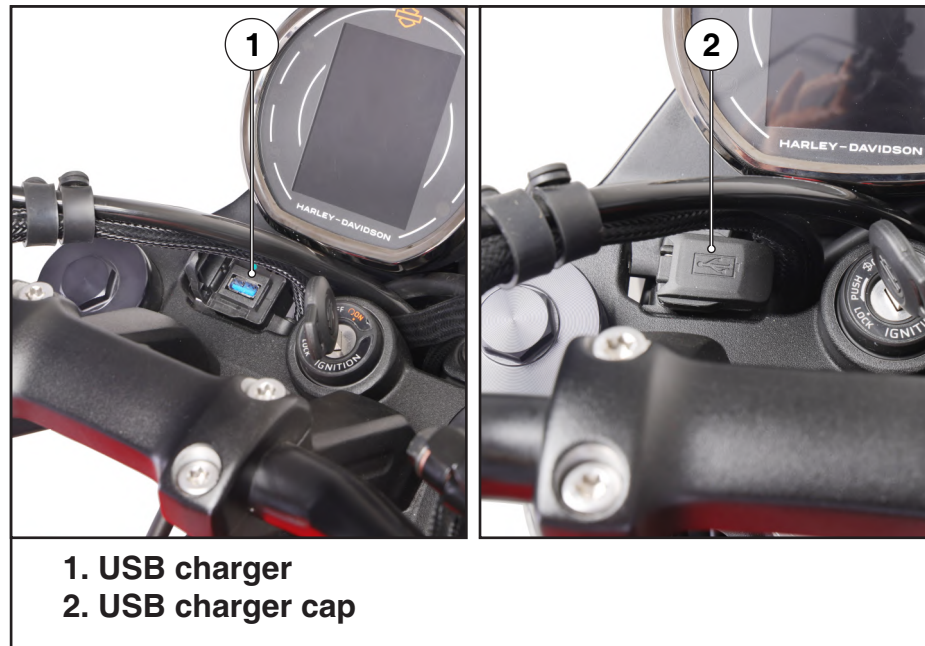

Figure 52. USB charger

⚠ CAUTION

- Always place the device in a safe and secure condition to avoid any damage due to road shocks while riding.
- Multiple charging of USB devices have to be avoided, simultaneous charging may lead to slow or no charging.
- USB port is for charging compatible USB devices.
- Do not leave the USB device and USB cable in the vehicle when the vehicle is parked.
- Charge your device when the engine is operational/ while riding.
- USB charger will not be covered under warranty in case of USB charger cap damage.



NOTE

- *Do not apply any soap solution, oil or grease inside the USB charger.*
- *Any personal belongings have to be removed before water washing to avoid damage.*
- *Always keep the USB port cap closed after use to prevent dust or water entry during rains/water wash.*
- *Do not direct water jet towards the port even with cap closed to avoid any short circuit. Always dry the area using a dry cloth or moisture free compressed air before use.*
- *Press the cap slightly for proper locking of USB charger cap.*
- *The charging time of mobile phone may vary, depending on the mobile phone's battery state of the charge, mobile phone make and conditions.*

PANIC BRAKE SIGNAL SYSTEM

The panic break signal system is a safety feature to alerts the traffic behind by activating the hazard light when the vehicle is braked rapidly and severely.

- The system is activated when (vehicle speed is more than 45 km/h and the vehicle deceleration at more than or equal to 6 m/s^2).
- The system shall be de-activated when (the vehicle deceleration has fallen below 2.5 m/s^2).

TRACTION CONTROL

How Traction Control Works

The Traction Control System (TCS) is designed to prevent the rear wheel from “spinning out” while accelerating.

Traction-control can improve rider confidence when available traction is reduced due to wet weather, a change in road surface or unpaved roads. Each pre-programmed ride mode has a specific level of TCS intervention.

During start-up, the traction-control lamp flashes simultaneously with the Anti-lock Braking System (ABS) lamp to indicate that the system is performing a wheel speed sensor check. The traction control system is operational during the wheel speed sensor check. After the sensor check is complete the traction control lamp should turn off.



How To Use Traction Control

NOTE

When running a vehicle on a dyno it is advised that traction control be disabled to prevent intervention based on tyre speed differences front to rear.

The TCS can be enabled or disabled using the left handle control switches ([page 53](#)). This adjustment can be made while the vehicle is stationary or in motion.

Changing to Rain Mode will automatically enable TCS. Once the TCS enabled the indicator (TC) will illuminate and remain illuminated until vehicle achieved the speed ≤ 5 km/hr. If the traction control lamp blinking fast while riding, it means the TCS is currently manage the wheel slip. However, if the TCS lamp remains on after 5km/hr speed it means the traction control system has faulted, In this event, please visit an authorized dealer for inspection.

STARTING THE ENGINE

Always follow the proper starting procedure described below :

- To protect the catalytic converter in your **H-D X440T** exhaust system, avoid extended idling and the use of leaded petrol.
- Your **H-D X440T** exhaust contains poisonous carbon monoxide gas. High levels of carbon monoxide can collect rapidly in enclosed areas such as garage. Do not run the engine with the garage door closed.

CAUTION

- **Never hold electric starter (Ⓢ) of integrated start-kill switch continuously more than 5 seconds as continuous cranking of engine will discharge the battery.**
- **This vehicle is equipped with a side stand engine kill feature ([page 61](#)).**

Preparation

Before starting the vehicle insert the key and follow the below mentioned procedure :

- See Figure 53. Turn the ignition switch (1) to "ON".
- See Figure 53. Confirm that the malfunction indicator lamp (MIL) (2) on meter console glows continuously and then should go "OFF" once the engine is started.



- See Figure 53. Find neutral position & check neutral (N) indicator (3) on instrument console with ignition "ON".



1. Ignition switch
2. MIL
3. Neutral indicator

Figure 53. Ignition switch/MIL/Neutral indication

NOTE

If MIL remains "ON" even if the vehicle is started, there is an abnormality in the vehicle. It is recommended to reduce the speed and drive to the an Authorized dealer for check-up.

- See Figure 54. Make sure that the integrated start-kill switch (4) is at "ON" (⊖) position.

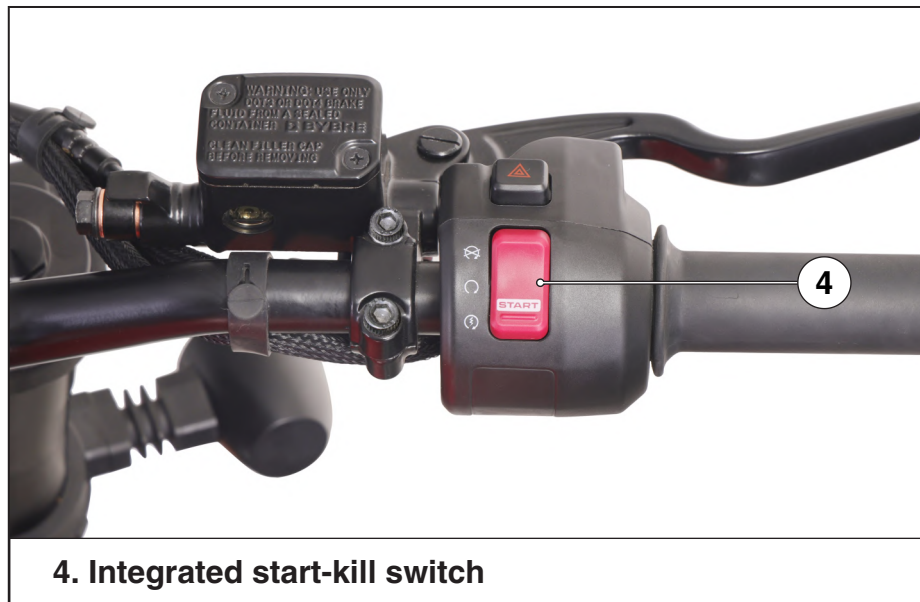

4. Integrated start-kill switch

Figure 54. Integrated start-kill switch

Starting procedure

At any ambient temperature, press the electric starter (⊖) of integrated start-kill switch with the throttle completely closed.

Flooded engine

If the engine fails to start after repeated attempts, it may be flooded with excess fuel.

1. Open the throttle fully.
2. Press the electric starter (⊖) of integrated start-kill switch for 5 seconds.



3. Follow the normal starting procedure.
4. If the engine starts with unstable idle, open the throttle slightly.
5. If the engine does not start wait for 10 seconds, then follow first 3 steps again.

Ignition cut off

Your **H-D X440T** is designed to automatically stop the engine & fuel pump, if vehicle falls down.

(Bank angle sensor cuts off the ignition).

NOTE

If the vehicle has fallen down, before restarting the engine you must turn the ignition switch to “OFF” (⊗) position and then back to “ON” (⊙) position.

Running in

Help assure your vehicle's future reliability and performance by paying extra attention to how you ride till first service.

During this period, avoid full-throttle and rapid acceleration.

NOTE

- *To start the engine, if any gear is engaged, press the clutch lever and press the integrated start-kill switch.*
- *Do not open the throttle during starting the vehicle.*

Operation 78

WARNING

Never run the engine in a closed area as the exhaust contains poisonous gases.

BRAKING

Anti-lock braking system (ABS)

This model is equipped with a Dual-channel ABS which enhances active safety by helping to prevent both the wheels from locking during braking.

ABS is designed to meet two essential requirements during every brake application:

- To help provide vehicle stability.
- To help maintain steering control and maneuverability—on road surfaces.

The ABS system is self-regulating and always active once vehicle speed exceeds 5 km/h provided ABS indicator lamp is “OFF” on the meter console.

- The ABS controller acts on the basis of the comparative speeds of the wheels. The use of non-approved tyres can affect the speed of the wheels and supply incorrect information to the ABS computer.

See Figure 55. The system has a wheel speed sensor on both the wheels, a hydraulic electronic control unit (HECU) (3), and an ABS indicator lamp (4) on meter console.



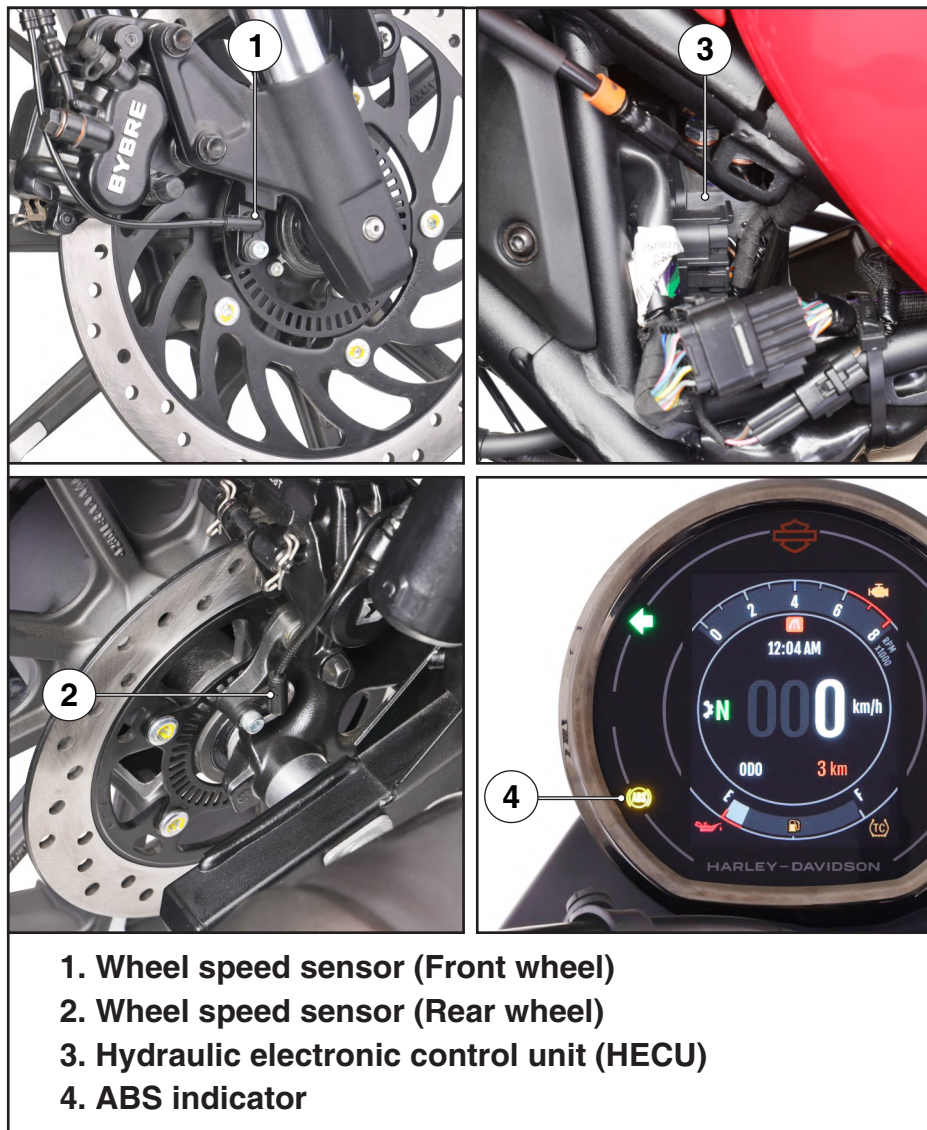

1. Wheel speed sensor (Front wheel)
2. Wheel speed sensor (Rear wheel)
3. Hydraulic electronic control unit (HECU)
4. ABS indicator

Figure 55. Anti-lock braking system (ABS)

Whenever you ride your **H-D X440T**, **wheel speed sensor** generates the rotation of wheel signal to **Hydraulic Electronic Control Unit (HECU)**. Then HECU calculates the speed of the wheel & vehicle, HECU becomes active when vehicle speed exceeds 5km/h. Now whenever you will apply front or rear brake, ABS will come into picture based on the input from respective wheel speed sensor, if wheel is getting locked, HECU will modulate the pressure at respective caliper thus avoiding wheel to lock and in turn resulting in safe stop of the vehicle.

Do's and Dont's

Do's

- Check your brake pads and be sure you have clean brake fluid. ABS systems can also fail due to worn brake pads or air or dirt in brake fluid.
- Use the recommended brake fluid.
- Rider is recommended not to ride at high speed when the brakes get wet. If brake gets wet, apply the brake while riding at low speed until the brakes are dry.
- It is recommended that ABS should be serviced at Authorized dealer.
- Read your Owner's Manual for additional riding instructions.
- Carefully remove the wheel during the puncture/tyre replacement to prevent any damage/bend to the sensor ring.
- Use only the recommended make, type, size of tyre and maintain specified tyre pressure ([page 21](#)).



- Keep checking the speedometer. In case of ABS malfunction, speed display may go to zero.
- Always maintain sufficient distance from the objects/vehicles ahead, for proper braking and to match the riding speed.
- On certain surfaces, such as rough road or gravel road, brake lever may have hard/ pulsating feel. Apply full braking on the lever even on the hard or pulsating feel of the lever to get the optimum performance.
- In case of ABS malfunction, the brake system will work as conventional (Non-ABS) brake. Rider is recommended not to apply hard brake to prevent wheel lock and visit an Authorized dealer.

Don't's

- Don't panic by mechanical noises or slight lever pulses while applying the brake (whenever ABS actuates) in vehicle. These conditions are normal and indicates that ABS is working.
- Don't apply the hard braking in wet or rainy conditions and while taking a turn.
- Do not adjust the wheel speed sensor air gap by yourself.
- Do not attempt to correct the encoder teeth by bending manually or by using any other mode. Do not use a different encoder teeth.
- Do not insert any metallic part the near wheel speed sensor.
- Don't try to service HECU, open it or separate/ disassemble the parts.
- Don't use the non-genuine spares like pads, discs, tyres etc.

Operation 80

NOTE

- *ABS may get activated without brake application while riding on uneven road surfaces (sharp drop or rise on the road level). This is normal functioning of ABS and not have any impact on performance.*
- *ABS may not work if the battery is discharged.*
- *ABS operation is also affected by road conditions, vehicle handling and brake operation. It is the user's responsibility to ride at reasonable speed and to leave a margin of safety.*
- *ABS consists of an electric motor, from which sound can be heard.*

WARNING

During extreme riding conditions, sometimes it is not possible to balance the vehicle (example- luggage loaded with higher center of gravity, varying road surfaces, hard braking without disengaging the gear).

Adapt your riding style to the road conditions and your riding ability as well.

RIDING

- Excessive revving of the engine during cold condition can reduce engine life.
- See Figure 56. While the engine is idling, press the clutch lever and depress the gearshift pedal downwards using the toe to shift into 1st gear.



- Slowly release the clutch lever and at the same time, gradually increase engine speed by opening the throttle. Coordination of the throttle and clutch lever will assure a smooth positive start.
- When the vehicle attains a moderate speed, close the throttle, press the clutch lever and shift to 2nd gear by placing the toe on the underside of gear pedal and lift upwards.
- This sequence is repeated progressively to shift to 3rd, 4th, 5th and 6th gear.

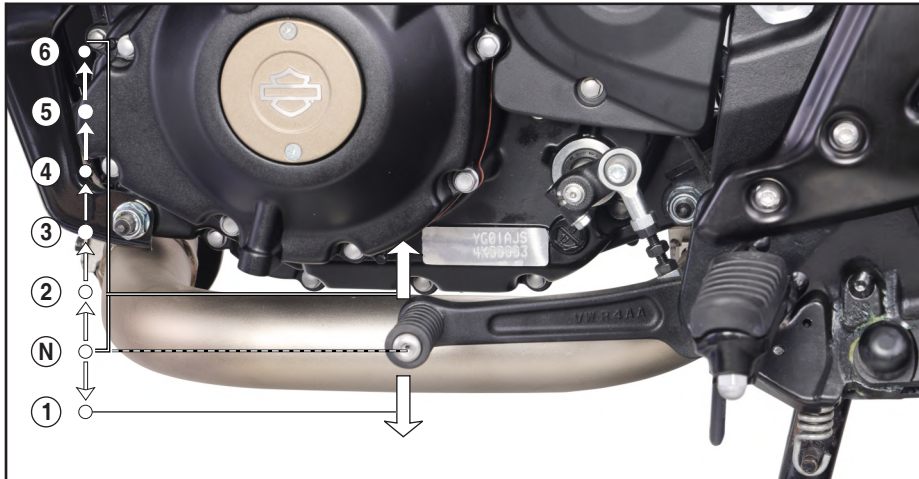

Figure 56. Gear shifting

⚠ CAUTION

Do not shift gears without operation of clutch and without closing the throttle otherwise this will lead to damage of gears.



NOTES



CLEANING AND WASHING OF VEHICLE

Follow the below mentioned steps for washing the vehicle.

- Wet the vehicle with light water spray. Avoid directing high pressure water spray to meter console, muffler outlets, electrical parts and oil cooler.
- Clean the headlamp lens and other plastic parts using a cloth or sponge dampened with a solution of mild detergent and water.
- After cleaning spray water thoroughly.
- Dry the vehicle by wiping with dry soft cloth.

NOTE

- *Our Authorized dealerships take all above mentioned precautions like usage of recommended detergents to ensure quality wash.*
- *While washing the vehicle, it is recommended to take necessary precaution to avoid damage to oil cooler and water entry into muffler.*

WARNING

Avoid direct high pressure water spray on any electrical, electronic components and oil cooler.

STORING VEHICLE

If the vehicle will not be operated for long duration, take steps to protect the vehicle. Always protect parts against corrosion, preserve the battery and prevent the build-up of gum and varnish in the fuel before storage.

Make a list of everything you do and fasten it to a handlebar grip. When you take the vehicle out of storage, this list is your reference/checklist to get your **H-D X440T** in operating condition.

WARNING

Do not store the vehicle with petrol in tank within the home or garage where open flames, pilot lights, sparks or electric motors are present. Petrol is extremely flammable and highly explosive, which could result in death or serious injury.



Take the following steps if H-D X440T not used for long duration:

- Change the engine oil.
- Empty the fuel tank into an approved petrol container using a commercially available hand siphon or an equivalent method.
- Spray the inside of the tank with an aerosol rust inhibiting oil.
- Reinstall the fuel filler cap on the tank.
- Remove the battery. Store in an area protected from freezing temperatures and direct sunlight. Charge the battery once a month.
- Wash and dry the vehicle. Coat chrome plated parts with rust inhibiting oil.
- Inflate the tyres to their recommended pressures. Park the vehicle on blocks to raise both tyres off the ground.
- Cover the vehicle (don't use plastic or other coated materials) and store in an unheated area, free of dampness with a minimum of daily temperature variation. Do not store the vehicle in direct sunlight.



MAINTENANCE

The importance of maintenance

A well-maintained vehicle is essential for safe economical and trouble-free riding. It will also help reduce pollution.

To help you, take proper care of **H-D X440T**, the following pages include a maintenance schedule and a maintenance record for regular scheduled maintenance.

These instructions are based on the assumption that the vehicle will be used exclusively for its designed purpose. Sustained high speed operation or operation in unusually wet or dusty conditions will require more frequent service than specified in the maintenance schedule. Consult your Authorized dealer for recommendation applicable to your individual needs and use. If your vehicle overturns or is involved in a crash, be sure that you visit your Authorized dealer for detailed inspections.

WARNING

- **Improperly maintaining your H-D X440T or failing to correct a problem before you ride can cause a crash in which you can be seriously injured or killed.**
- **Always follow the inspection and maintenance recommendations and schedules in this Owner's Manual.**

Maintenance safety

This section includes instructions on some important maintenance tasks. You can perform some of these tasks with the tools provided (if you have basic mechanical skills).

Other tasks that are more difficult and require special tools are best performed by professionals. It is recommended that wheel removal should normally be handled by an Authorized dealer.

You will come across some of the most important safety precautions in the following pages of this manual.

However, we cannot warn you of every conceivable hazard that can arise in performing maintenance. Only you can decide whether or not you should perform a given task.

WARNING

- **Failure to follow maintenance instructions and precautions properly can seriously injure you.**
- **Always follow the procedures and precautions in this Owner's Manual.**



SAFETY PRECAUTIONS

- **Make sure the engine is “OFF” before you begin any maintenance or repair. This will help to eliminate several potential hazards:**
 - **Carbon monoxide poisoning from engine exhaust.**
Be sure there is adequate ventilation whenever you operate the engine.
 - **Burns from hot parts.**
Let the engine and exhaust system cool before touching.
 - **Injury from moving parts.**
Do not run the engine unless instructed to do so.
- **Read the instruction before you begin and make sure you have the tools and skills required.**
- **To help prevent the vehicle from falling over, park it on a firm, level surface on the main stand (optional).**
- **To reduce the possibility of a fire or explosion, be careful when working around petrol or batteries. Use only nonflammable solvent, not petrol, to clean parts. Keep cigarettes, sparks and flames away from the battery and all fuel-related parts.**

Remember that your Authorized dealer knows your H-D X440T best and is fully equipped to maintain and repair it.

To ensure best quality and reliability, it is recommended to use genuine parts for repair and replacement.



MAINTENANCE SCHEDULE

Perform the pre-ride check list (**page 25**) at each scheduled maintenance period.

I: INSPECT C: CLEAN R: REPLACE A: ADJUST L: LUBRICATE T: TOP UP E: EMISSION CHECK

The following maintenance schedule specifies all maintenance required to keep your **H-D X440T** in peak operating condition. Maintenance work should be performed in accordance with standards and specifications of Harley-Davidson by properly trained and equipped technicians. Your Authorized dealer meets all of these requirements.

Ensure that each paid service is availed within **12 months** or **10000 km** from the date of previous service, whichever is earlier.

 To be serviced by your Authorized dealer unless the owner has the relevant tools, technical information and is technically qualified.

 In the interest of safety, we recommend that these jobs are carried out only by your Authorized dealer.

Note-1 : At higher odometer readings, repeat the frequency interval established here.

Note-2 : Service more frequently if the vehicle is ridden in unusually wet or dusty areas.

Note-3 : Replace engine oil once in every 10000 km. Top up if the oil level is at or near the lower level mark.

Note-4 : Strainer cleaning has to be ensured at defined frequency at 1st Service and all service at 10000 km frequency.
Engine oil filter to be replaced at 1st Service and in every 10000 km.

Note-5 : Visit Authorized dealer for inspection, cleaning, lubrication and adjustment of drive chain at every 1000 km or as required.

Note-6 : Replace brake fluid once in every two years or 30000 km, whichever is earlier.

Note-7 : Inspect & maintain specified torque.

Note-8 : Inspect the bearings free play, replace if necessary.

Note-9 : Replace tyre as per TWI.

Note-10 : Replace rubber washer once in every 2 years or 10000 km.

Note-11 : Replace front fork oil once in every 2 years or 30000 km, whichever is earlier.

Note-12 : Inspect rear suspension mounting bushes play, replace rear shock absorber if necessary.

Note-13 : Check CO emission at idle, to be followed Govt. regulation (PUC).

Note-14 : Inspect the canister hoses for deterioration, damage or loose connections and canister for cracks or other damages.

Note-15 : Clean the Magnetic Drain Plug bolt tip in every 10000 km/during oil change/oil replace if any damages.

Note

- Service more frequently if the vehicle is ridden in wet or dusty areas.
- Service more frequently if the vehicle is ridden in rain or at full throttle.
- Always wipe the water from the vehicle after washing. Use clean soft cloth or pressurized air for completely drying the water.
- Always replace gaskets, O-rings, circlips and cotter pins with new one once removed.









Replacement of parts (e.g filters, etc.) and consumables (e.g engine oil, etc.) during paid or free service are at customer's expenses.



MAINTENANCE SCHEDULE

Dear Customer,

We would strongly recommend the following schedule, to keep your **H-D X440T** in perfect running condition and healthy environment. Vehicle subjected to severe use or ridden in dusty area will require more frequent servicing.

ITEMS	WHICHEVER COMES FIRST	#DURING FREE SERVICE PERIOD			DURING PAID SERVICE PERIOD ONCE IN EVERY 10000 KM/ 12 MONTHS
	SERVICE	1 st	2 nd	3 rd	
	DAYS	1st 60	6 Months	12 Months	
	KM Note-1	500-750	5000	10000	
Fuel Line		I	I	I	I
 Throttle Operation		I	I	I	I
 Air Cleaner Element	Note-2	I	I	R	R
Spark Plug		I, C, A	I, C, A	R	R
 Valve Clearance		I, A	I, A	I, A	I, A
Engine Oil	Note-3	R	I, T	R	R
 Engine Oil Strainer Screen	Note-4	C		C	C
 Engine Oil Filter	Note-4	R		R	R
 Engine Oil Cooler		I	I	I	I
Electric Starter		I	I	I	I
Oil Circulation		I	I	I	I
 Drive Chain	Note-5	I, C, L, A at every 1000 km or early as required			
Drive Chain Slider		I	I	I	I
Battery Voltage		I	I	I	I
Brake Shoe/Pad Wear		I	I	I	I
 Brake System & Brake Pedal Pivot		I, C, L	I, C, L	I, C, L	I, C, L



ITEMS	WHICHEVER COMES FIRST	#DURING FREE SERVICE PERIOD			DURING PAID SERVICE PERIOD ONCE IN EVERY 10000 KM/ 12 MONTHS	
	SERVICE	1 st	2 nd	3 rd		
	DAYS	1st 60	6 Months	12 Months		
	KM Note-1	500-750	5000	10000		
	Brake Fluid	Note-6	I	I	I	I
✘	Stop Lamp Switch		I	I	I	I
✘	Headlamp Focus		I, A	I, A	I, A	I, A
	Clutch Free play		I, A	I, A	I, A	I, A
	Side Stand/Main Stand (optional)		L	L	L	L
	Side Stand Switch		I, C	I, C	I, C	I, C
🔧	Nut, Bolts & Fasteners (grommets and dampers)	Note-7	I	I	I, R (If required)	I, R (If required)
✘	Wheels & Flange bearings	Note-8	I	I	I	I
✘	Wheels cast	Note-9	I	I	I	I
✘	Tyre	Note-9	I	I	I	I
✘	Steering Head Bearing	Note-10	I	I, A	I, L, A	I, L, A
✘	Front Suspension/Oil	Note-11	I	I	I	I
🔧	Rear suspension	Note-12	I	I	I	I
✘	Muffler (Catalytic Converter)	Note-13		I, E	I, E	I, E
🔧	Evaporative Emission Control System	Note-14	I	I	I	I
✘	Magnetic Drain Plug bolt tip	Note-15	C		C	C
✘	Fuel filter (external)				R	R



TOOL KIT

See Figure 57. The tool kit (1) is located on the utility cover inside right side cover. Some emergency repairs, minor adjustment and parts replacement can be performed with the tools contained in the kit.

Remove the right side cover ([page 113](#)).



Figure 57. Tool Kit/ First aid kit location

See Figure 58. Kit consists of following tool:

- **Tool bag (1)** -To keep all the tool in one place.
- **Driver (2)** -To tighten/loosen the screw.
- **Grip (3)** - To hold the +, - No. 2 Driver.
- **Box wrench P16x14 (4)** -To loosen/tighten the spark plug.
- **Spanner 12-14 mm (5)** -For clutch cable adjustment and mirror adjustment.
- **Pin spanner (6)** -To adjust the pre load of rear shock absorber.
- **Handle pin spanner (7)** -To hold the pin spanner.
- **Fuse puller (8)** -To remove the fuse from the vehicle.
- **Spanner 8-10 mm (9)** -For throttle cable free play adjustment
- **Allen key 5 mm (10)** -For seat, battery cover and frame cover removal.





Figure 58. Tool Kit

FIRST AID KIT

See Figure 57. The first aid kit (2) is located on the utility cover inside right side cover. For some emergency first aid can be performed by medicine contained in the kit.

Remove the right side cover ([page 113](#)).

Kit contains the following items :

- Antiseptic cream-1 No.
- Sterilised dressing-1 No.
- Water proof plaster-1 No.
- Elastic bandage-1 No.
- Gauze (Rolled bandage)-1 No.
- Sterilised elastic plaster-1 No.
- First aid bag-1 No.
- Hemostatic agent-1 No.



SPARK PLUG INSPECTION

Recommended plugs: Federal Mogul REK6YC

For most riding conditions this spark plug heat range number is satisfactory. However, if the vehicle is going to be operated for extended periods at high speeds or near maximum power in hot climates, the spark plug should be changed to a cold heat range number, consult an Authorized dealer on this if required.

- Clean dirt around the spark plug base.
- See Figure 59. Disconnect the noise suppressor cap (1) and remove the spark plug (2) with the help of spark plug box wrench provided in the tool bag.
- Visually inspect the spark plug electrodes for wear. The center electrode should have square edges and the side electrode should not be eroded. Discard the spark plug if there is apparent wear or if the insulator is cracked or chipped.
- Make sure that the spark plug gap is **0.8-0.9 mm** using a wire-type feeler gauge. If adjustment is necessary, bend the side electrode carefully. Make sure the plug washer is in good conditions.

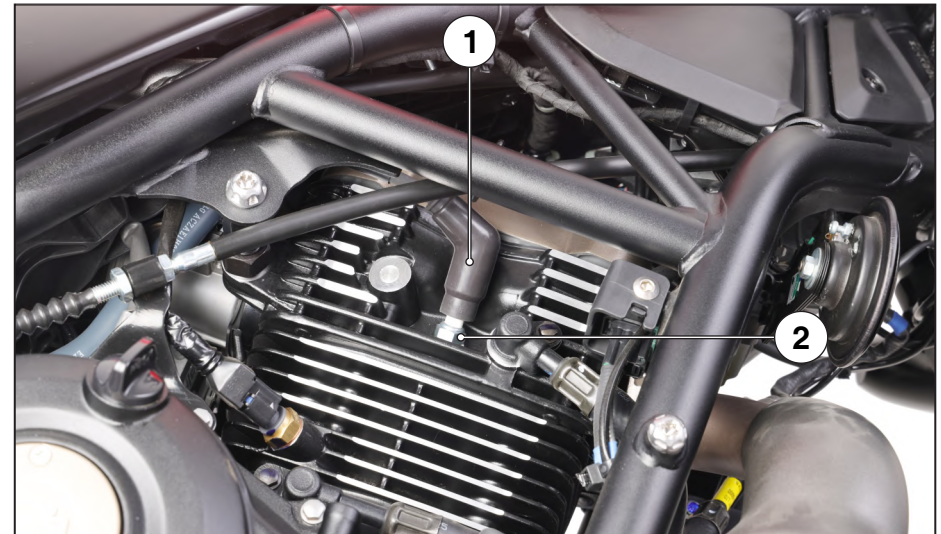

1. Noise suppressor cap
2. Spark plug

Figure 59. Spark plug

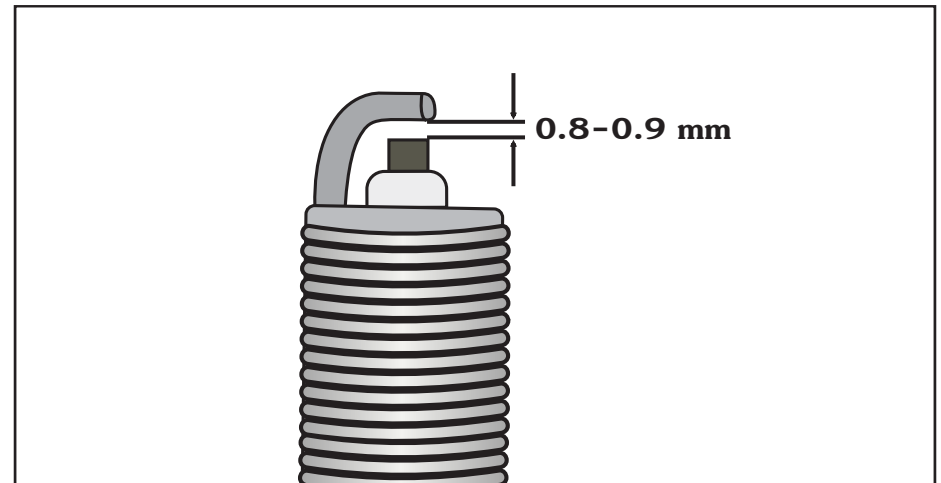

- With the plug washer attached, thread the spark plug in by hand to prevent cross- threading.
- Tighten a new spark plug 1/2 turn after the plug seats, with a spark plug box wrench to compress the washer. If you are reusing a plug, it should only take 1/8-1/4 turn after the plug seats.

CAUTION

- **Do not remove the spark plug and test for spark on the vehicle by cranking the engine as this could lead to fire or explosion**
- **Never use a spark plug with improper heat range.**
- **Install a dummy spark plug in the cylinder head and test for spark.**
- **Always use resistor type spark plug.**

ENGINE OIL

Use genuine engine oil or recommended grade oil.

BRAND: Harley-Davidson X

GRADE: 100% Synthetic SAE 15W 50

Manufactured by (recommended):

- Indian Oil Corporation Limited.
- Savita Oil Technologies Limited.

OIL CAPACITY :

2.6 litres (at disassembly)

2.25 litres (at draining)

Engine oil level inspection/

Top up process

See Figure 60. Check engine oil level each day before operating the vehicle. The oil level window (1) is on the right crankcase cover for measuring oil level. Oil level must be maintained between the upper (2) and lower (3) level marks on the oil level window.

See Figure 60. Add the specified oil by removing the oil filler cap (4) and filling till the upper level mark (2). Do not overfill.





1. Oil level window
2. Upper level mark
3. Lower level mark
4. Oil filler cap

Figure 60. Engine oil level inspection

- Do top up if oil level reaches towards the lower level mark or every 5000 km whichever is earlier.
- Park the vehicle on its main stand (optional).
- Start the engine & let it idle for 3-5 minutes.
- See Figure 61. Slightly loosen the engine oil check bolt (5) and check the engine oil entry into the cylinder head.

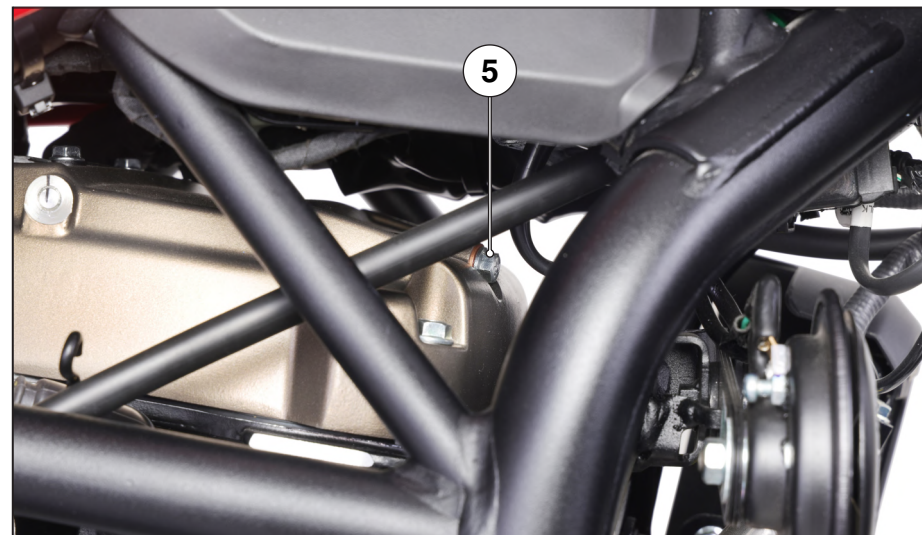

5. Engine oil check bolt

Figure 61. Engine oil level inspection

- After checking the oil circulation, tighten the engine oil check bolt.
- Stop the engine and wait for 2-3 minutes.
- Check the oil level in the oil level window.
- If required, add the specified oil up to the upper level mark. Do not overfill.
- Reinstall oil filler cap with new O-ring and check for oil leaks.



Engine oil replacement/Oil circulation inspection

- Start the engine, warm it up for several minutes and then turn it off.
- Wait a few minutes until the oil settles down.
- See Figure 62. To drain the oil, remove the oil filler cap, drain bolt (6) and sealing washer (7).

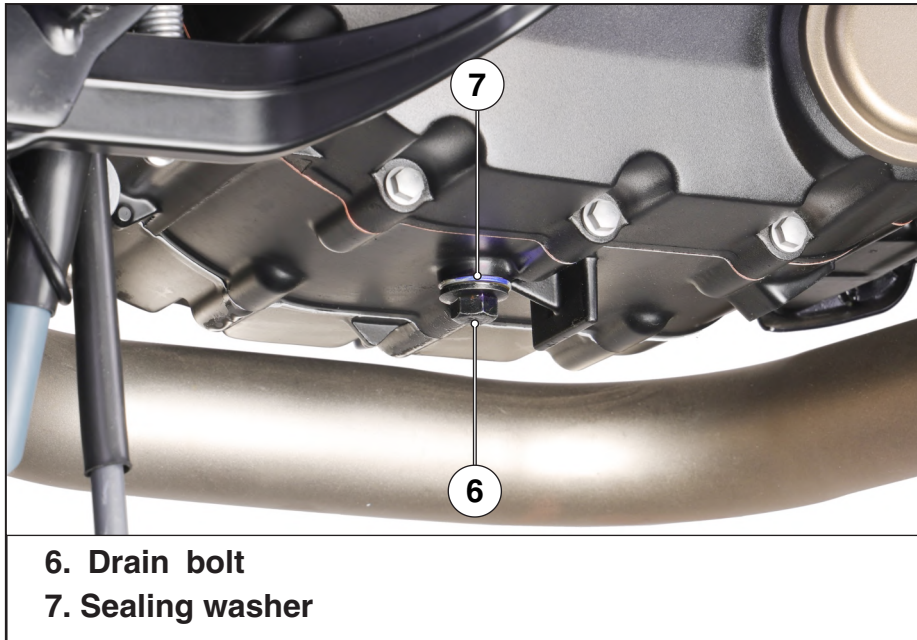

Figure 62. Engine oil replacement

- After the oil is completely drained, reinstall the drain bolt (6) with a new sealing washer (7).
- Fill the crankcase through the oil filler hole with 2.25 litres (approximately) of the recommended grade oil as the right crankcase cover is not removed.
- Reinstall the oil level filler cap with a new O-ring.
- Start the engine and allow it to idle for few minutes.
- Stop the engine and let the engine oil settle down.
- Recheck the oil level.
- Make sure that oil level is at the “UPPER” level mark of the oil level window with the vehicle in an upright position and that there are no oil leaks.

⚠ CAUTION

- **Engine oil is a major factor affecting the performance and service life of the engine. Non-detergent, vegetable or castor based racing oils are not recommended.**
- **Running the engine with insufficient oil can cause serious engine damage.**
- **Running the engine with excessive oil can cause spark plug fouling & loss in performance.**



ENGINE OIL FILTER ELEMENT

NOTE

Drain the engine oil thoroughly ([page 111](#)) in case of engine oil filter element replacement.

- See Figure 63. Remove the two mounting bolts (1).
- See Figure 63. Remove the engine oil filter element cover (2) with O-ring (3).

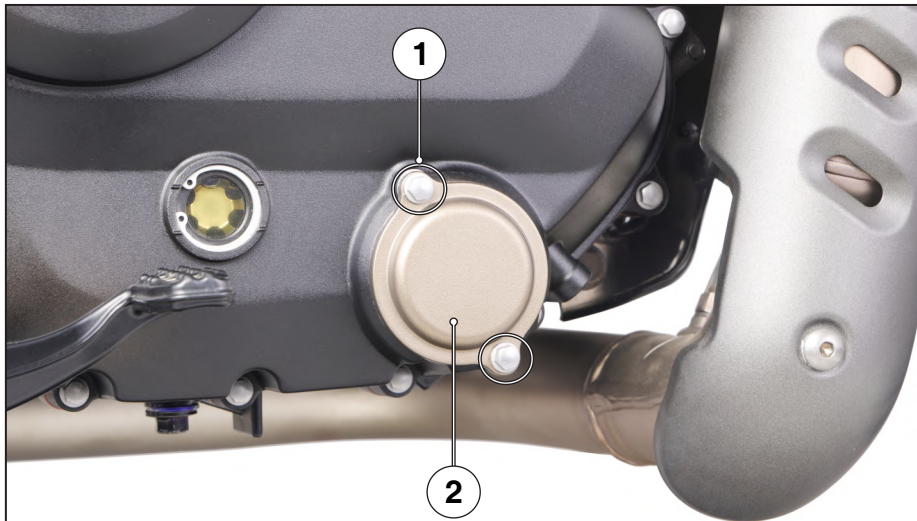

- 1. Mounting bolts
- 2. Engine oil filter element cover

Figure 63. Engine oil filter replacement

- See Figure 64. Remove the engine oil filter element (4) from the cover.
- See Figure 64. Replace the engine oil filter element (4).

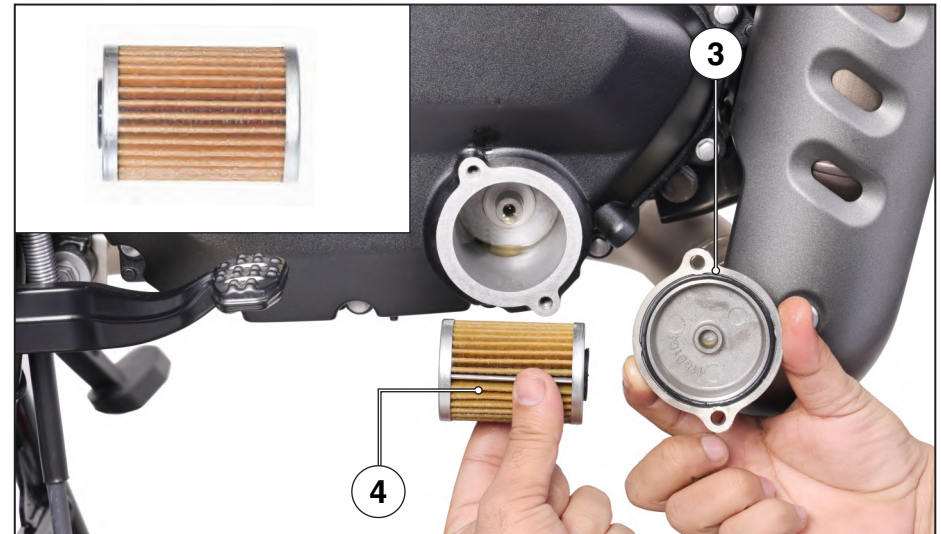

- 3. O-ring
- 4. Engine oil filter element

Figure 64. Engine oil filter replacement

NOTE

- When the engine oil filter element is replaced always replace the O-ring with the new one.
- Make sure that O-ring is properly seated.
- Apply engine oil on engine oil filter element before installation.
- Inspect and replace engine oil filter element as specified in the maintenance schedule.
- Installation is in the reverse order of removal.



ENGINE OIL COOLER

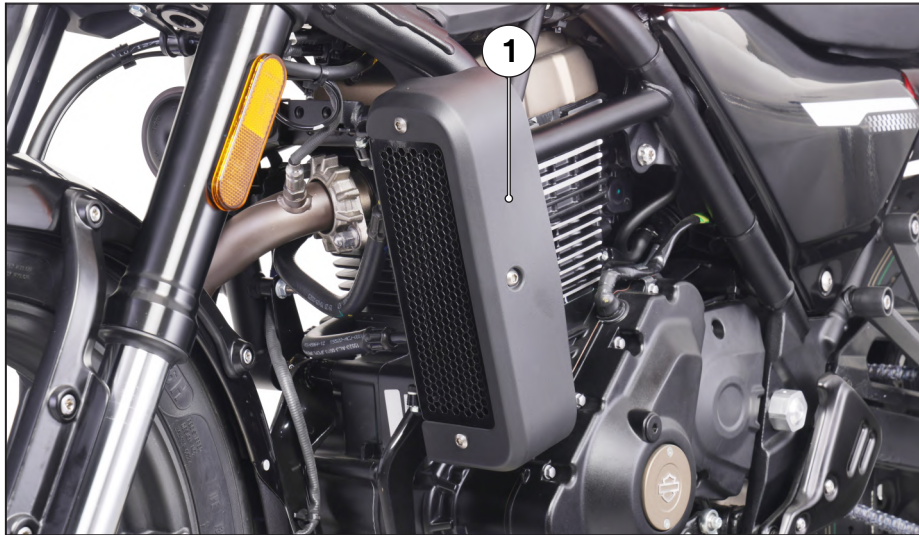

1. Engine oil cooler

Figure 65. Engine oil cooler

CAUTION

- No hard objects to be used for cleaning the engine oil cooler (1), otherwise the fins will get damaged.
- No high pressure washing of the oil cooler as it may damaged the fins, any physical contact with fins is to be avoided.
- Avoid keeping any cloth or flammable object between hot parts (muffler, oil cooler, engine).

AIR CLEANER

Air cleaner element inspection

Refer to the safety precautions (page 102).

The air cleaner element is of wet paper pleated type, it should be serviced at specified intervals (page 103). Service more frequently when riding in unusually wet or dusty areas.

- See Figure 66. Remove the right side cover (1) by inserting the ignition key (2) in to the lock and turn it to clockwise and releasing the lug from the grommet and release tab from the slot.

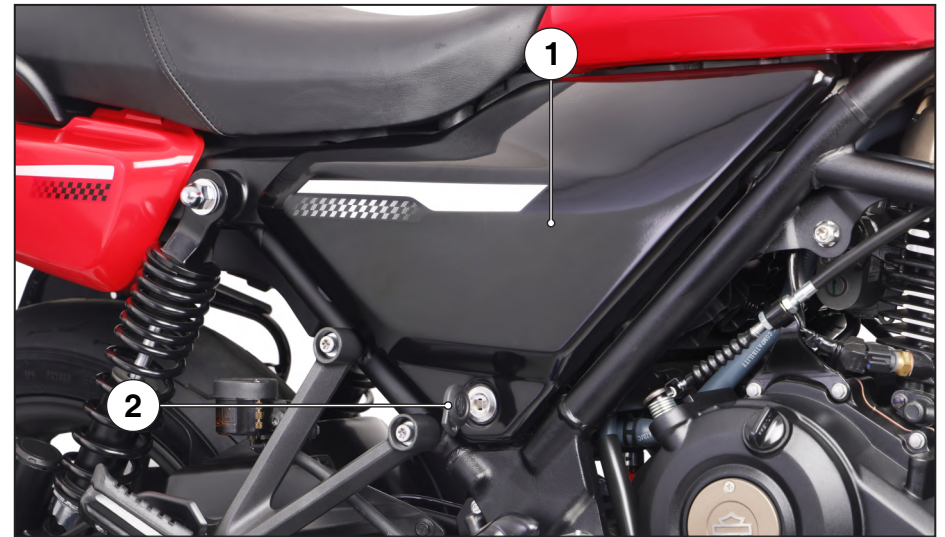

1. Right side cover
2. Ignition key

Figure 66. Right side cover removal



- See Figure 67. Dislodge the seat catch cable (3) from the stay (4) and remove the cable from the utility box slot (5).
- See Figure 67. Remove the two allen key bolts (6) and remove the utility box (7) by dislodging the lug from the grommet.

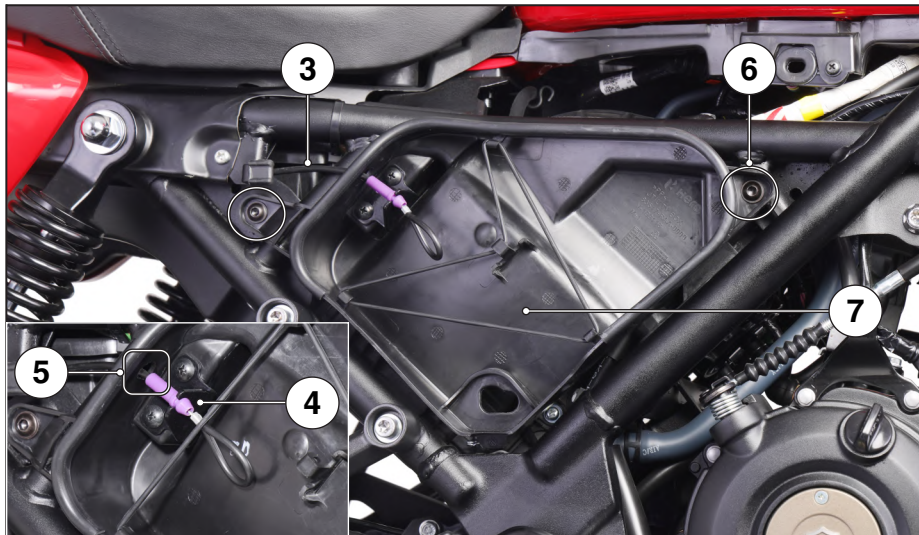

- 3. Seat catch cable
- 4. Seat catch cable stay
- 5. Utility box slot
- 6. Allen key bolts
- 7. Utility box

Figure 67. Utility box removal

- See Figure 68. Remove the four air cleaner cover screws (8) and remove the air cleaner cover (9).

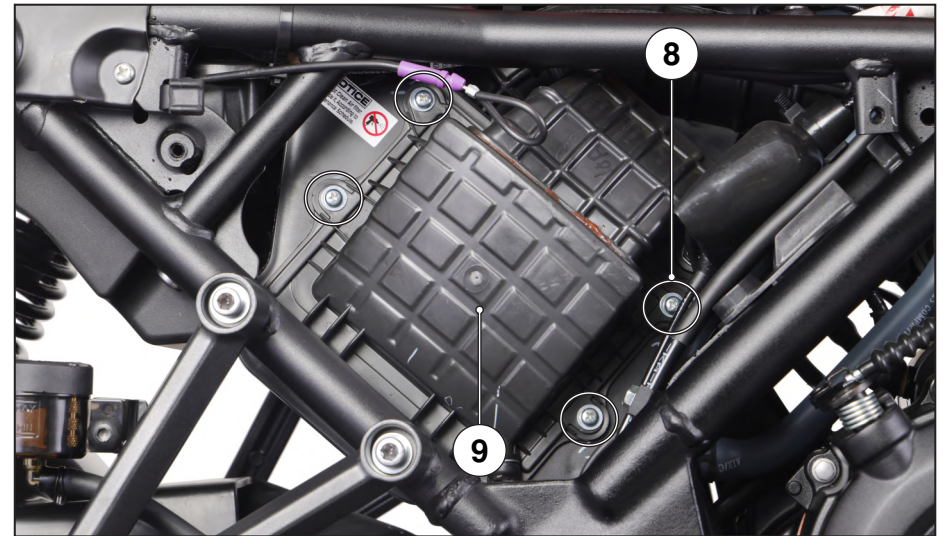

- 8. Screws
- 9. Air cleaner cover

Figure 68. Air cleaner cover removal



- See Figure 69. Remove the air cleaner element (10) from air cleaner housing (11).



Figure 69. Air cleaner element removal

⚠ CAUTION

- Never wash or clean the wet, paper pleated type filter. Replace filter element once in every 10000 km.
- Replace it earlier if it becomes very dirty, damaged on surface or on the sealing area.

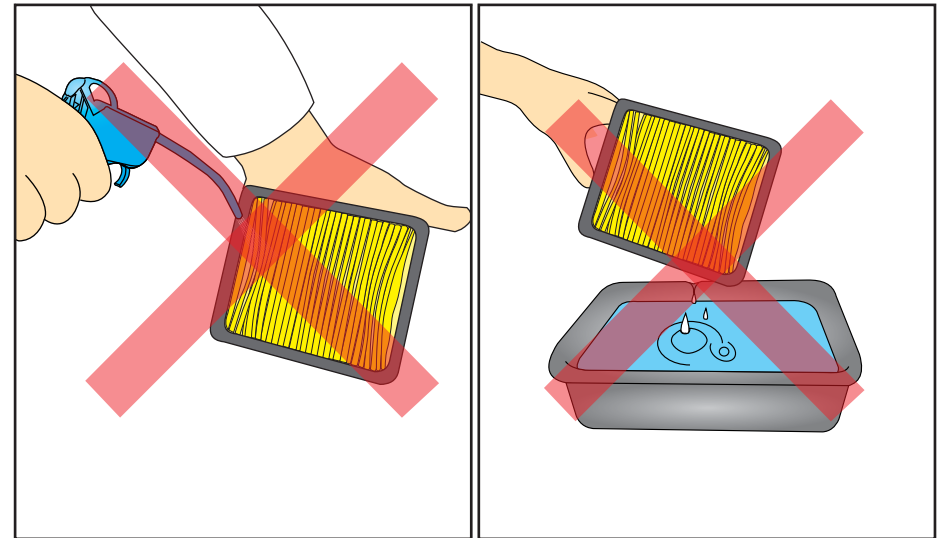

- Install the air cleaner element.
- Install the air cleaner element cover.
- Install the utility box.
- Install the seat catch cable.
- Install the right side cover.



Air cleaner drain tube cleaning

See Figure 70. Remove the drain tube (1) and drain the deposit into a container.

Follow the above process more frequently when riding in rain or at full throttle.

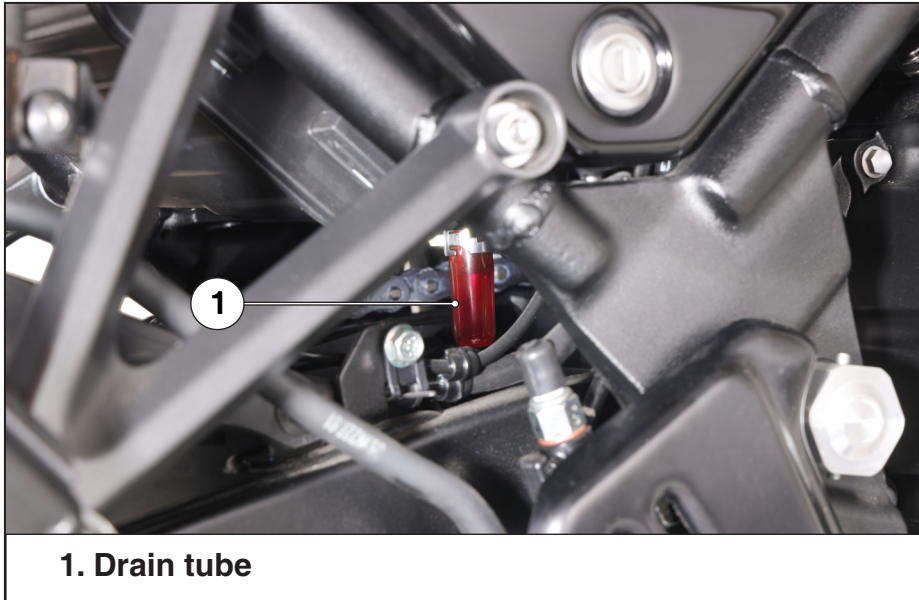

Figure 70. Drain tube cleaning

NOTE

Always ensure to reinstall the drain tube after draining the deposit.

VALVE CLEARANCE

Engine valve clearance changes with use, which may result in improper air-fuel mixture and /or engine noise. To prevent this, the valve clearance must be adjusted at an Authorized dealer at the intervals specified in the maintenance schedule ([page 103](#)).

CLUTCH LEVER FREE PLAY

Adjustment

Clutch adjustment may be required if the vehicle stalls when shifting into gear or tends to creep or if the clutch slips, causing acceleration to lag behind engine speed. See Figure 71. Normal clutch lever free play (1) is 10-15 mm at the lever (2).

- See Figure 72. To adjust the free play, loosen the lock nut (3). Turn the adjusting nut (4) to obtain the specified free play. Tighten the lock nut and check the adjustment.
- Start the engine, press the clutch lever and shift into gear. Make sure the engine does not stall, and the vehicle does not creep. Gradually release the clutch lever and open the throttle. The vehicle should start smoothly and accelerate.





- 1. Free play:10-15 mm
- 2. Clutch lever

Figure 71. Clutch lever free play

NOTE

If proper adjustment cannot be obtained or the clutch does not work correctly, visit your Authorized dealer.

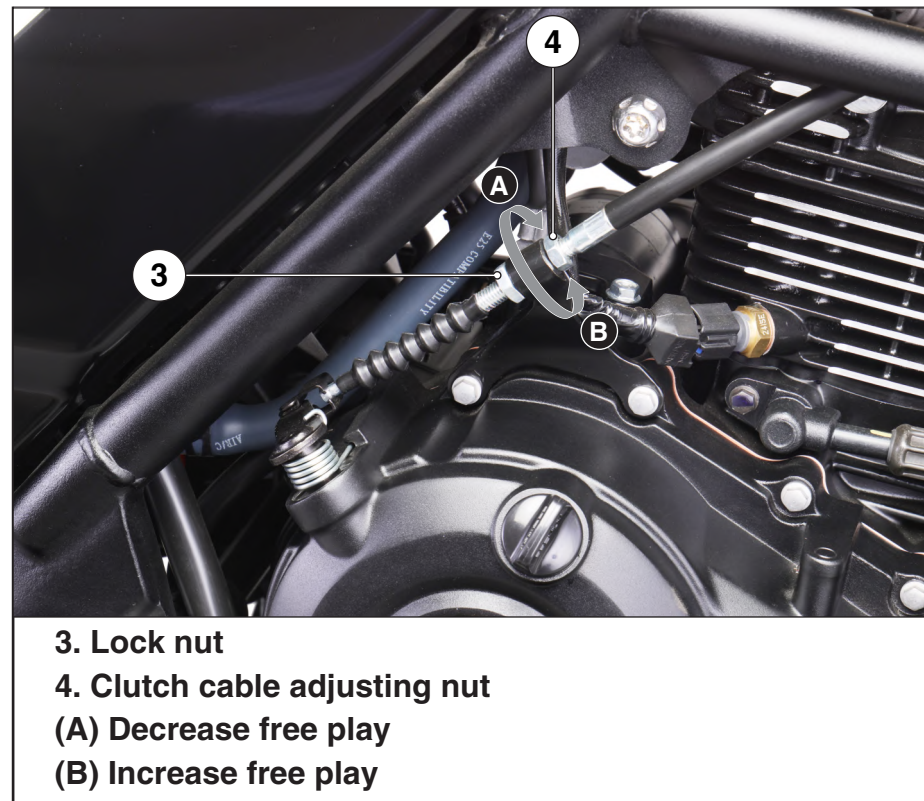

- 3. Lock nut
- 4. Clutch cable adjusting nut
- (A) Decrease free play
- (B) Increase free play

Figure 72. Clutch lever free play adjustment

Other checks

- Check the clutch cable for kinks or signs of wear that could cause sticking or failure.
- Check for clutch cable model. Use genuine clutch cables.
- Check for clutch cable routing.



DRIVE CHAIN SLACKNESS

The service life of the drive chain depends upon proper lubrication and adjustment.

Poor maintenance can cause premature wear or damage to the drive chain and sprockets.

See Figure 73. The drive chain (1) should be checked and lubricated as part of the pre-ride checklist (page 25). Under severe usage, or when the vehicle is ridden in unusually dusty areas, more frequent maintenance will be necessary.

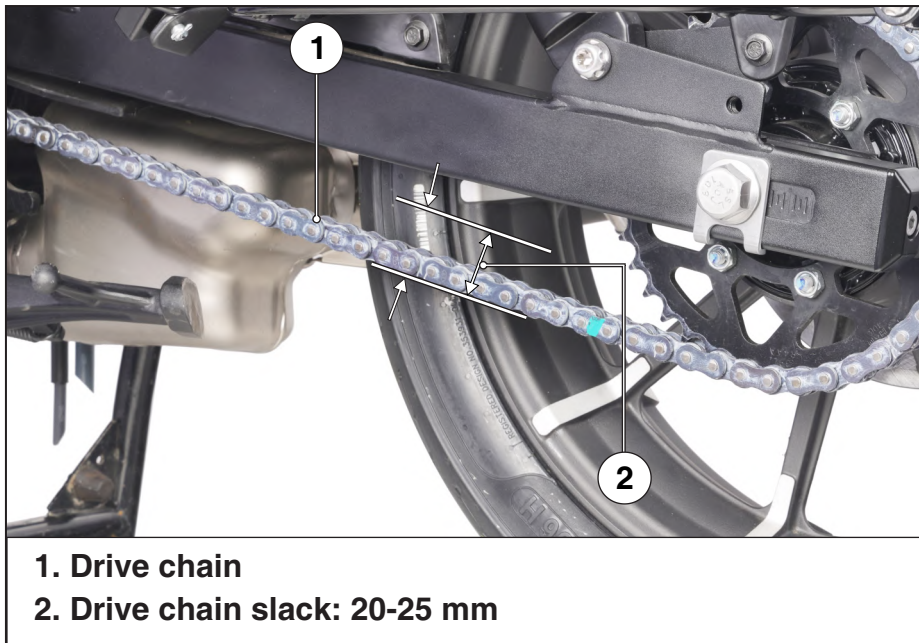

Figure 73. Drive chain slackness

Inspection

- Turn the engine “OFF”, park the vehicle on its main stand (optional) and shift the transmission to neutral.
- See Figure 73. Drive chain slack (2) should be checked in the lower run midway between the sprockets. Move the drive chain up and down by hand and chain slack should be adjusted to 20-25 mm vertical movement by hand.

NOTE

Drive chain slack should be adjusted at your Authorized dealer as per the specification.

- Rotate the rear wheel slowly and inspect the drive chain and sprockets for any of the following conditions.

Drive chain

- Damaged rollers
- Loose pins
- Dry or rusted links
- Kinked or binding links
- Excessive wear
- Improper adjustment
- Damaged or missing O-rings.



Sprockets

- Excessively worn teeth
- Broken or damaged teeth.
- If the drive chain has damaged rollers, loose links or missing O-rings, replace it. If the chain is dry or rusted, it should be lubricated.

Lubricate the chain if the links are kinked or binding. If the problem is not solved after lubrication, replace the chain.

If the drive chain or sprockets are excessively worn or damaged, they should be replaced.

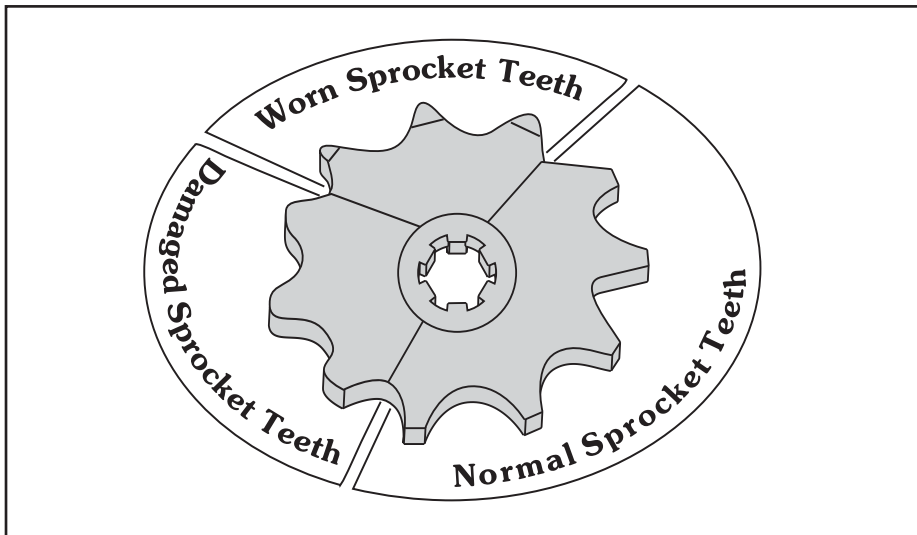

⚠ CAUTION

Always replace the drive chain and sprockets as a set. Otherwise the new part will wear prematurely.

Adjustment

Drive chain slack should be checked and adjusted, if necessary at every 1000 km.

When operated at sustained high speeds or under conditions of frequent rapid acceleration, the chain may require more frequent adjustments.

If the drive chain requires adjustment, follow the procedures below:

- Park the vehicle on its main stand (optional) with the transmission in neutral and the ignition switch in “OFF” position.
- See Figure 74. Loosen the rear axle nut (1).

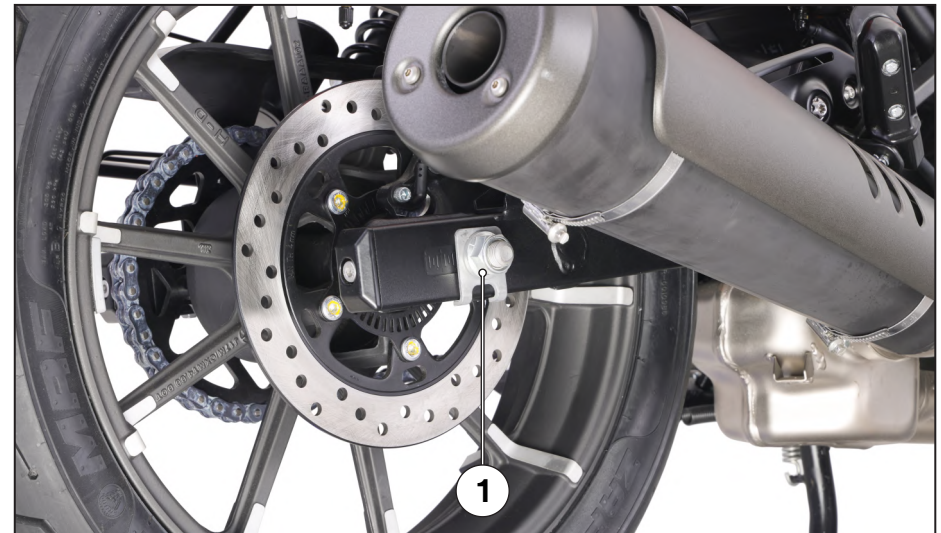

1. Rear axle nut

Figure 74. Drive chain slackness adjustment



- See Figure 75. Loosen the drive chain adjusting allen bolt [5 mm] (3) from both side.
- See Figure 75. Turn the adjusting allen bolt [5 mm] (3) in an equal number of turns, on left and right sides, until the correct drive chain slack is obtained. Turn the adjusting allen bolt [5 mm] clockwise to decrease the slack or anticlockwise to increase the slack of the chain.
- See Figure 75. Equally align the chain adjuster index mark (4) with the rear edge (5) of the adjusting slots on both sides of the swingarm.
- Tighten the rear axle nut.

Torque: 11 kgf-m

- Check the drive chain slack again.
- See Figure 75. If after adjustment of drive chain slack, axle (2) touches to the rear edge of adjustment slot (5) chain kit has to be replaced.

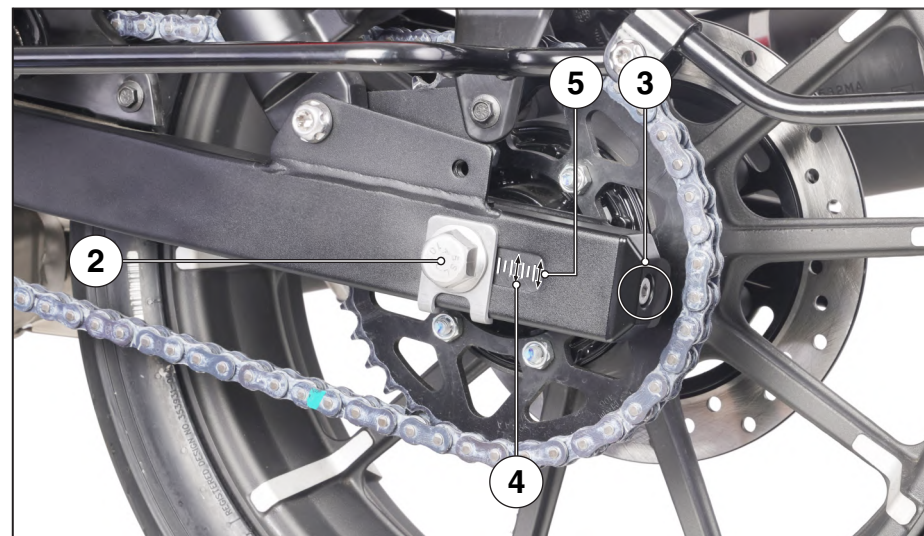

- 2. Axle
- 3. Drive chain adjusting allen bolt [5 mm]
- 4. Index mark
- 5. Rear edge of adjusting slot

Figure 75. Drive chain slackness adjustment

⚠ WARNING

If a torque wrench is not used for installation, see your Authorized dealer as soon as possible to check for proper assembly.



Cleaning and Lubrication

Lubricate every 1000 km or sooner if the chain appears dry.

- Turn the engine off, park the vehicle on its main stand (optional) and shift the transmission into neutral. Open side stand to facilitate cleaning.
- Spray a commercially available chain cleaner for cleaning the drive chain over its entire length.

NOTE

Ensure that the chain cleaner and lubricant used is the one recommended for use on an O-ring chain, otherwise the O-rings may deteriorate, fail or lose their sealing properties.

- Rotate the rear wheel backwards to expose the next section of the drive chain and repeat second step until all of the drive chain is cleaned.
- Let the spray dry for about five minutes.
- To remove stubborn dirt, scrub the rollers and side plates with soft nylon brush.
- Apply SAE 90 grade oil on the hanger side of the entire length of the chain using an oil can.
- Wait for 7-10 minutes for penetration of lubricant inside the bush and roller, wipe the excessive lubricant from the chain and near by parts using a clean rag.

NOTE

Excessive lubricant if not wiped off, will aid in accumulation of dust, sand and dirt on the drive chain, increasing its wear. Excessive lubricant may also be sprayed on the vehicle as well due to chain movement.

⚠ CAUTION

- **Steam cleaning, high pressure washers and certain solvents can damage the drive chain O-rings.**
- **While lubricating and cleaning, hold the rear wheel with one hand to prevent the possibility of your finger being trapped between the chain and sprocket.**
- **Clean and lubricate the chain, whenever possible, after riding the vehicle under rain or in terrain with excessive dust, mud or sand.**
- **The drive chain is fitted with O-rings between the link plates. These O-rings retain grease inside the chain to improve its service life. However, special precautions must be taken when adjusting, lubricating, washing and replacing the chain.**
- **If the chain is excessively dirty, it should be removed and cleaned before lubrication. For your own safety, we recommend that service be performed by an Authorized dealer.**



DRIVE CHAIN SLIDER INSPECTION

(Refer to “Maintenance Schedule” on [page 103](#)).

See Figure 76. Check the chain slider (1) for wear, The chain slider must be replaced if wear limit (2) is reached. For replacement, see your Authorized dealer.

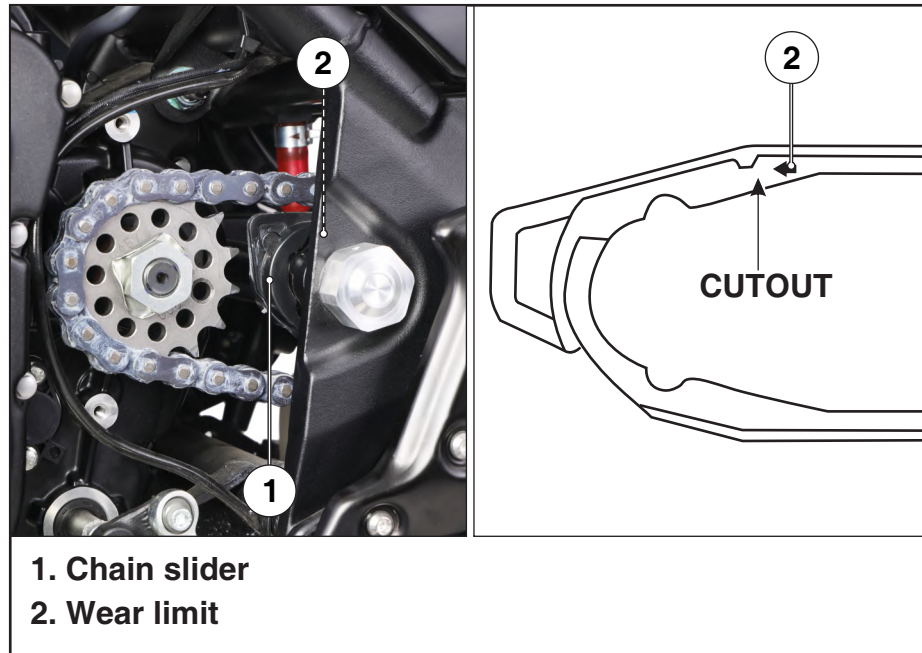

Figure 76. Drive chain slider inspection

BRAKES

(a) Front brake

Refer to the safety precautions on ([page 102](#)).

See Figure 77. Master Cylinder/Reservoir (1)

Location : Right handlebar.

Brake fluid recommended: DoT-4

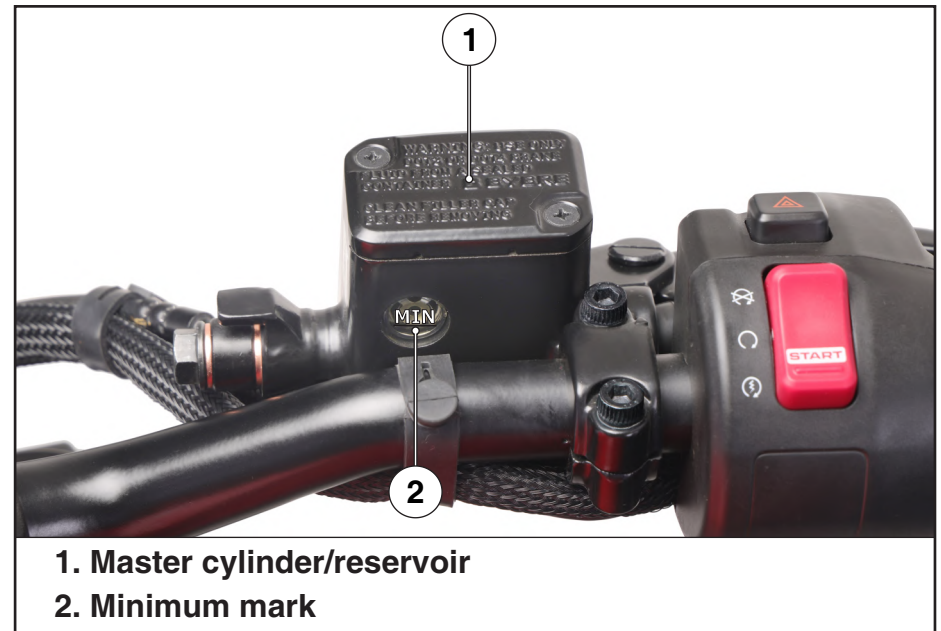

Figure 77. Master cylinder/reservoir



Fluid level - Ensure that the brake fluid level does not fall below "MIN" (minimum) mark (2) on master cylinder, when checked with the master cylinder parallel to the ground. See Figure 78. The level decreases gradually due to piston movement to compensate pad wear. If the level decreases abruptly, check for the leakages in the brake system and consult your Authorized dealer.

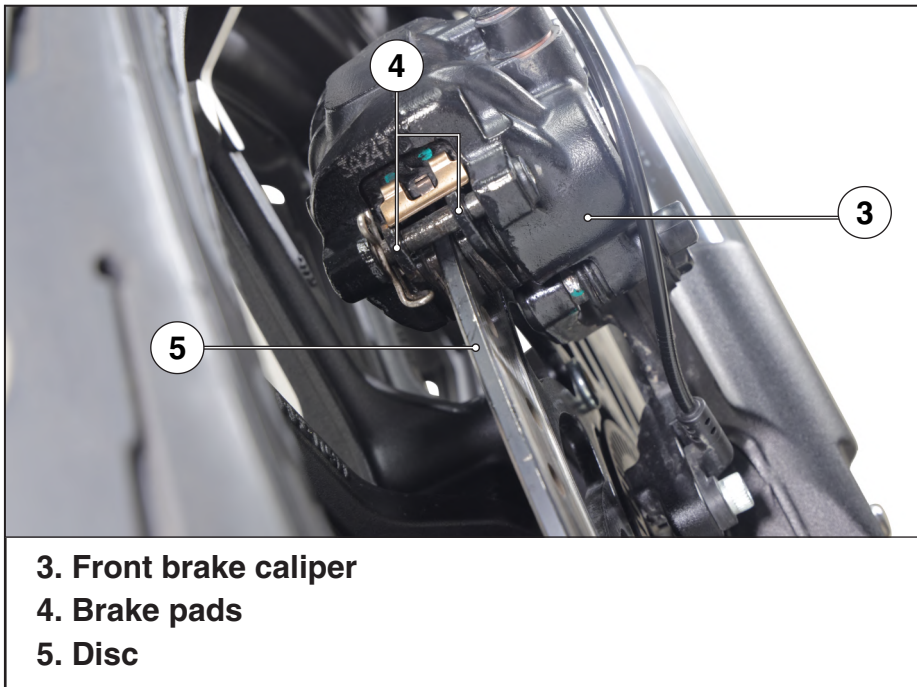

Figure 78. Front brake caliper/Pad/Disc

NOTE

- See Figure 78. Clean the dirt and mud accumulation between the front brake caliper (3), brake pads (4) and the disc (5) by using a water jet.
- Always contact your Authorized for refilling of master cylinder/reservoir when necessary.
- Always use recommended tyres ([page 21](#)) for better braking performance.

(b) Rear brake

Refer to the safety precautions on ([page 102](#)).

See Figure 79. Reservoir (1)

Location: Above the rear brake master cylinder.

Brake fluid recommended :

DoT-4

Fluid level - Ensure that the brake fluid level does not fall below "MIN" mark (2) on the reservoir parallel to the ground. See Figure 79. The level decreases gradually due to piston movement to compensate pad wear. If the level decreases abruptly, check for the leakages in the brake system and consult your Authorized dealer.





1. Reservoir
2. Minimum mark

Figure 79. Reservoir

NOTE

- See Figure 80. Clean the dirt and mud accumulation between the rear brake caliper (3), brake pads (4) and the disc (5) by using a water jet.
- Always contact your Authorized dealer for refilling of reservoir when necessary.

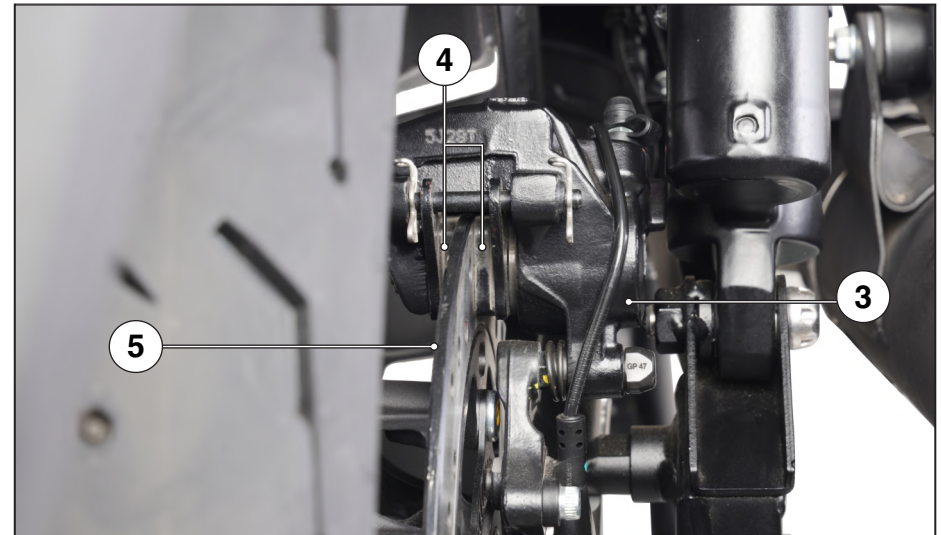

3. Rear brake caliper
4. Brake pads
5. Disc

Figure 80. Rear brake caliper/Pad/Disc

(c) Brake pad wear

Brake pad wear depends upon the severity of usage, type of riding & road conditions. Generally, the pads will wear faster on wet & dirty roads. Inspect the pads as per maintenance schedule, however more frequent inspection is recommended if used in wet and dirty roads.



Front brake

- See Figure 81. Check the brake pads for wear by examining the wear indicator groove (1) on each pad.
- If either pad is worn to the bottom of the grooves replace both pads as a set. Visit your Authorized dealer for this service.

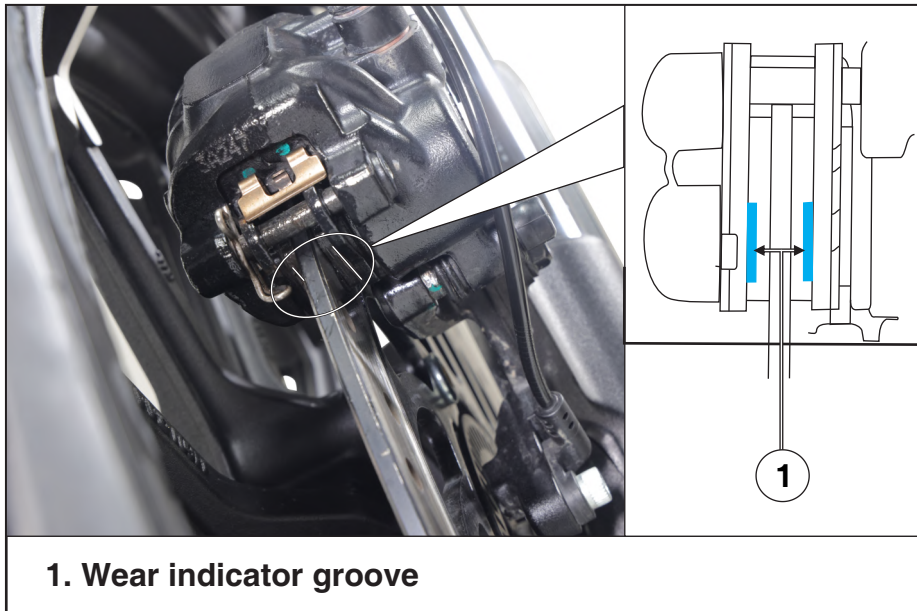

Figure 81. Front brake pad wear

Rear brake

- See Figure 82. Check the wear indicator groove (1) in each pad. If either pad is worn to the bottom of the groove, replace both as a set. Visit your Authorized dealer for this service.

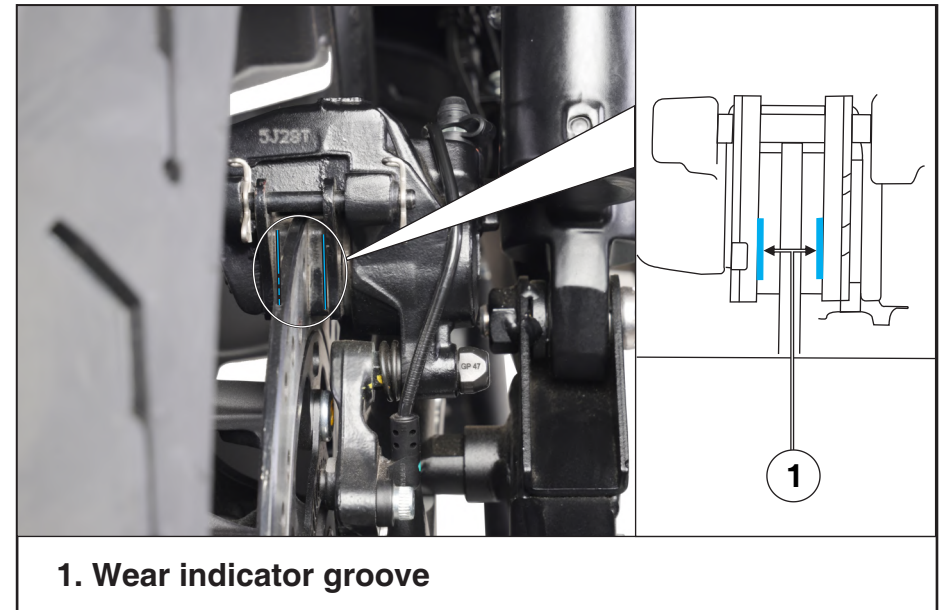

Figure 82. Rear brake pad wear

WARNING

Always apply front and rear brakes simultaneously to avoid skidding of vehicle.



MAIN STAND (OPTIONAL)/ SIDE STAND LUBRICATION

- Park the vehicle on the level surface.
- Check the main stand (optional)/side stand return spring for damage or loss of tension.
- See Figure 83. Check the main stand (1) (optional)/side stand (2) for freedom of movement.
- Lubricate the main stand (optional)/side stand.
- Make sure the main stand (optional)/side stand is not bent.

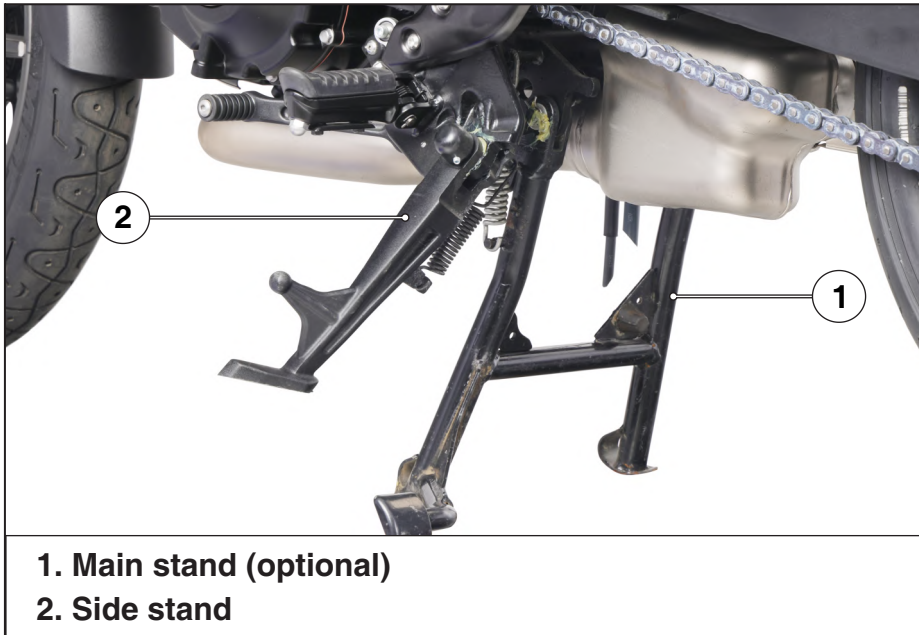

Figure 83. Main stand (optional)/Side stand

NUTS, BOLTS & FASTENERS

- Tighten bolts and nuts as per maintenance schedule.
- Check that all chassis nuts and bolts are tightened to correct torque values.
- Check that all cotter pins, safety clips, hose clamps and cable stays are in place.



BATTERY

Refer to the safety precautions on [\(page 102\)](#).

Location

The battery is located below the seat.

Specification

*MF Battery-12V-8 Ah/ETZ-9

It is not necessary to check the battery electrolyte level or add distilled water as the battery is a **Maintenance-Free (sealed)** type. If your battery seems weak and/or electrolyte is leaking (causing hard starting or other electrical troubles), contact your Authorized dealer.

NOTE



This symbol on the battery means that this product must not be treated as household waste.



This symbol on the battery means the old battery must be returned to your Authorized dealer as it must be treated as recyclable material.

- *Battery is a maintenance-free (sealed) type and can be permanently damaged if the sealing strip is removed.*
- *An improperly disposed battery can be harmful to the environment and human health. Always confirm local regulations for battery disposal.*

***MF stands for Maintenance Free**

Battery charging

Always visit your Authorized dealer if you see any symptom of battery discharge as earliest as possible to get the battery charged. The battery has a tendency to discharge rapidly if additional electrical accessories are fitted on the vehicle.

Battery storage

- If in case your **H-D X440T** is not used for more than a month remove the battery, fully charge and store in a cool and dry place.
- If the battery is expected to be stored for more than two months, ensure to fully charge the battery once in a month.
- Always ensure the battery is fully charged before installation.
- Ensure the battery leads are properly connected to the battery terminals during installation.



Battery removal

- Make sure the ignition switch is “OFF” (⊗).
- Remove the right side cover (page 113).
- See Figure 84. Dislodge the seat (1) by pulling the seat catch cable (2) and release the seat from the seat catch (3).
- See Figure 84. Pull the seat from the rear side and remove the seat by sliding it backward.



Figure 84. Seat removal

- See Figure 85. Remove the DLC cover (4). Remove the battery cover six allen bolts (5).

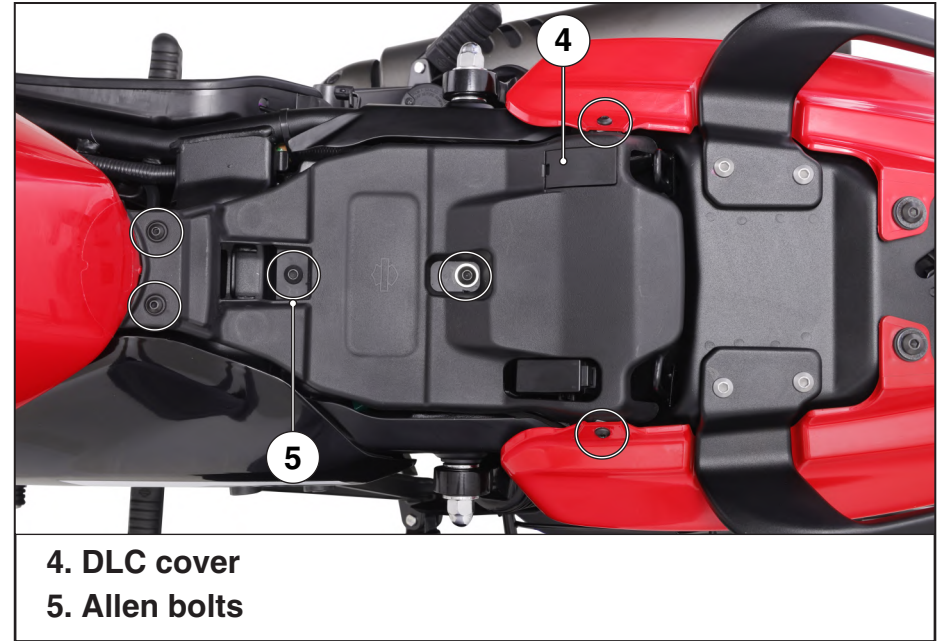
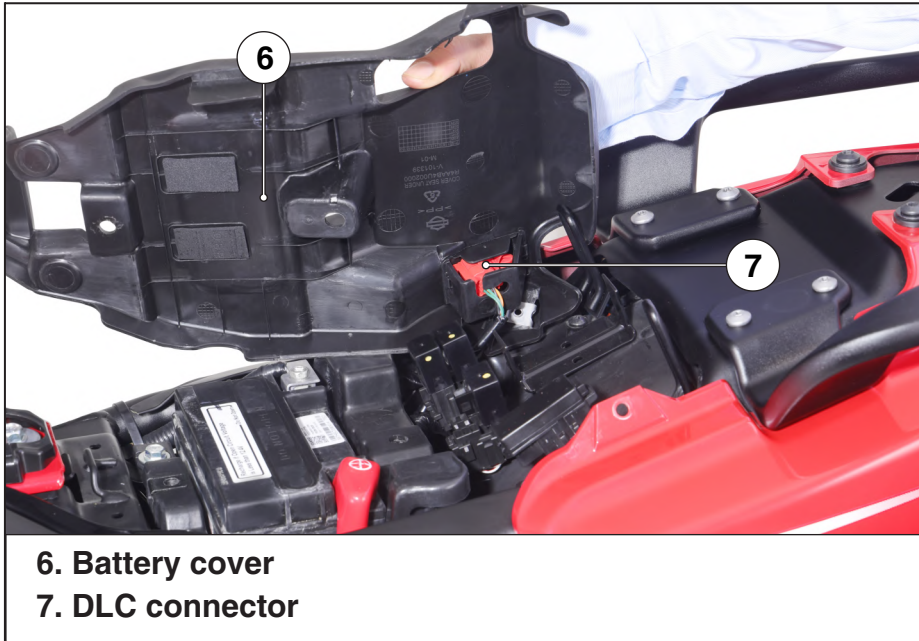

Figure 85. Battery cover removal



- See Figure 86. Remove the battery cover (6). by removing the DLC connector (7).



6. Battery cover
7. DLC connector

Figure 86. Battery cover removal

- See Figure 87. Disconnect the (-)ve terminal lead (8) from the battery first, then disconnect the (+)ve terminal lead (9).
- See Figure 87. Pullout the battery (10) from the battery box.

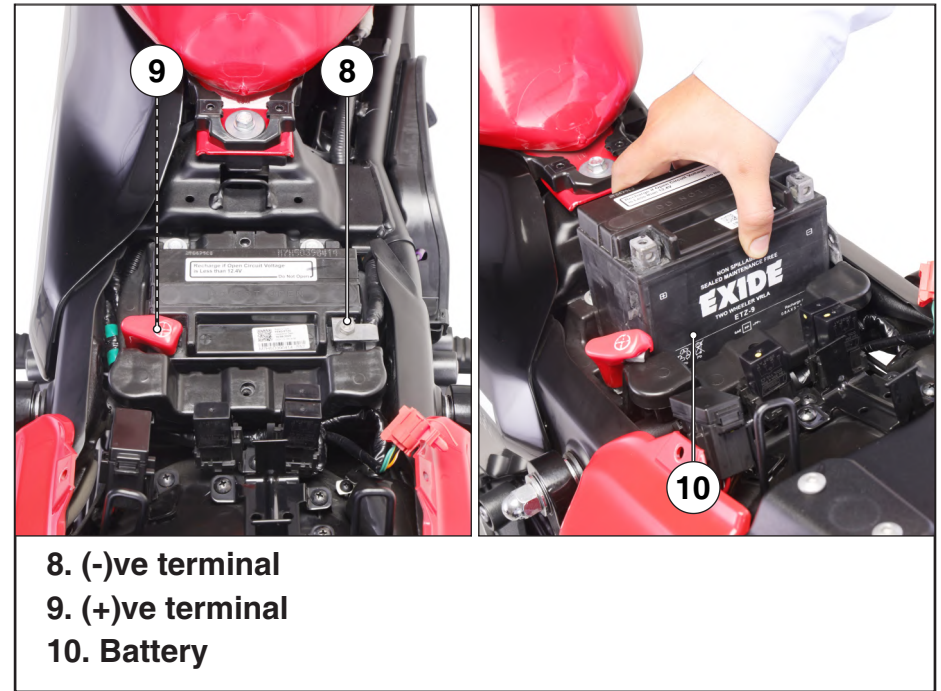

8. (-)ve terminal
9. (+)ve terminal
10. Battery

Figure 87. Battery removal

Battery installation

- Reinstall in the reverse order of removal. Be sure to connect the (+)ve terminal first, then the (-)ve terminal.
- Check all bolt and other fasteners are secured properly.

NOTE

During battery installation, always assemble the battery carefully so that +ve terminal should be always fitted on the designated harness terminal.



FUSE REPLACEMENT

Refer to the safety precautions on [\(page 102\)](#).

See Figure 88. Fuse box (1)

Location: Below the seat.

Fuse type: Blade fuse

Main fuse (2) : 15A x3 nos. & 10A x3 nos.

Spare fuse (3) : 15A, 10A, 25A

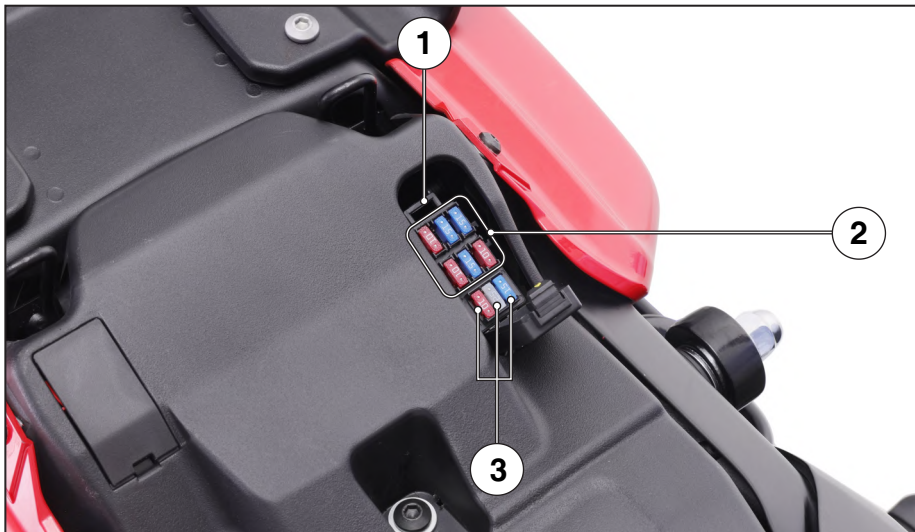

1. Fuse box

2. Main fuse : 15A x 3 nos. & 10A x 3 nos.

3. Spare fuse : 15A, 10A, 25A

Figure 88. Fuse box

See Figure 89. Starter magnetic switch (4)

Location : Below the battery

Fuse type: Blade fuse

Remove the water protector cover (5).

Main fuse (6) : 25A

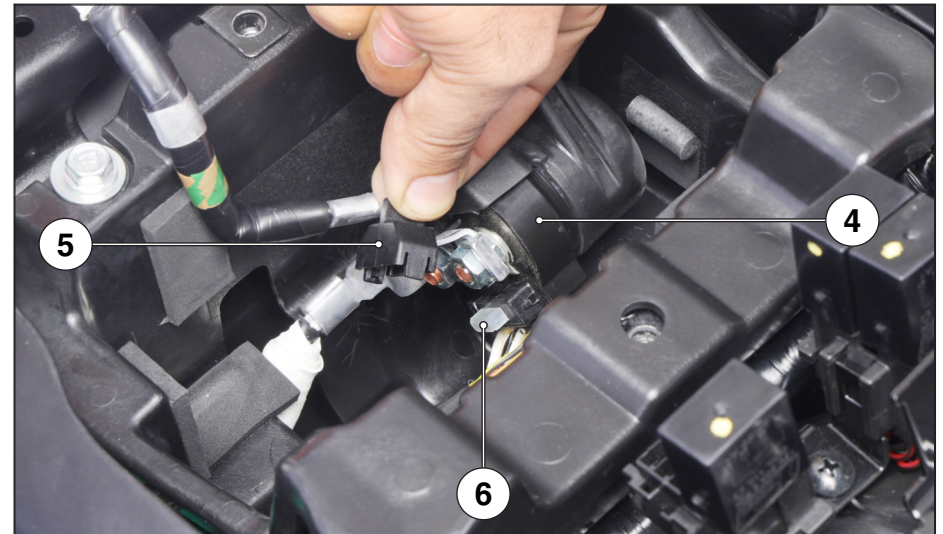

4. Starter magnetic switch

5. Water protector cover

6. Main fuse: 25A

Figure 89. Starter magnetic switch



⚠ WARNING

- Never use a fuse with a different rating from that specified. It may lead to serious damage to the electrical system or a fire due to short circuit.
- Battery gives off explosive gases. Keep sparks, flames & cigarettes away.

⚠ CAUTION

- Do not attempt to start or ride the vehicle without a charged battery, it can cause fusing of the LEDs and permanent damage to certain electrical components.
- Turn the ignition switch "OFF" before checking or replacing the fuse to prevent accidental short-circuiting.

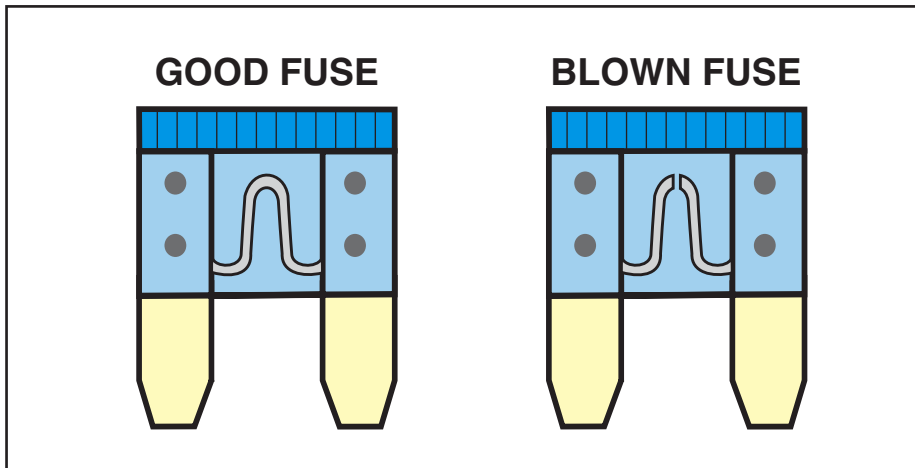

HEADLAMP FOCUS ADJUSTMENT

Headlamp is preset. However in case of adjustment required, please follow the steps as given below:

- See Figure 90. Headlamp adjustment is done by loosening the bolt (1) located below the headlamp.
- Park the vehicle on its main stand (optional) on level ground.
- Turn the ignition switch to "ON" position () and start the engine.
- Adjust the headlamp beam by loosening the bolt (1) and moving the headlamp unit forward and backward for correct focus adjustment.
- Tighten the bolt after adjustment.

⚠ WARNING

An improperly adjusted headlamp may blind oncoming rider/driver or it may fail to light the road for a safe distance.





1. Headlamp adjusting bolt

Figure 90. Headlamp adjustment

GEARSHIFT PEDAL ADJUSTMENT

Your H-D X440T is equipped with a gearshift pedal that can be set to the desired angle and reach.

See Figure 91. To adjust gearshift pedal (1) angle, loosen the lock nuts (2) by rotating clockwise direction and turn the adjusting nut (3) by rotating clockwise or anti-clockwise direction until the desired angle is obtained. Tighten the lock nuts.

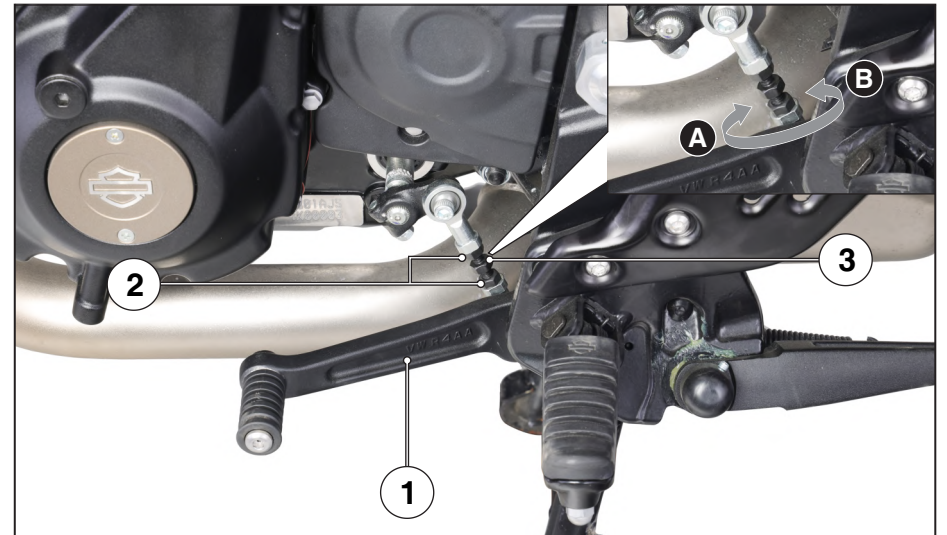

1. Gearshift pedal

2. Lock nuts

3. Adjusting nut

(A) Clockwise direction

(B) Anti-clockwise direction

Figure 91. Headlamp adjustment



CATALYTIC CONVERTER

Your **H-D X440T** is equipped with a catalytic converter (1) in the muffler to meet the emission norms. See Figure 92.

The catalytic converter contains precious metals that serve as catalysts, promoting chemical reactions to convert the exhaust gasses without affecting the metals. The catalytic converter acts on HC, CO and NOx. The catalytic converter must operate at a high temperature for the chemical reactions to take place. It can set on fire any combustible material that come near it. Park your **H-D X440T** away from high grasses, dry leaves, or other flammable material.

A defective catalytic converter contributes to air pollution and can impair your engine's performance.

Follow these guidelines to protect your **H-D X440T** catalytic converter.

- Always use unleaded petrol. Even a small amount of leaded petrol can contaminate the catalyst metals, making the catalytic converter ineffective.
- Keep the engine in good running condition. A poorly running engine can cause the catalytic converter to overheat.
- If your engine is misfiring, backfiring, stalling, or otherwise not running properly, stop riding and turn "OFF" the engine. Have your **H-D X440T** serviced as soon as possible.

⚠ CAUTION

Avoid keeping any cloth or flammable object between or around hot parts (such as muffler, oil cooler, engine).



1. Catalytic converter

Figure 92. Catalytic converter



EVAPORATIVE EMISSION CONTROL SYSTEM

Your **H-D X440T** is equipped with an evaporative emission control system to meet emission standards. During warm weather, the petrol vapours which contain HC evaporates easily into the atmosphere from the fuel tank, if the fuel system is unsealed or open.

The evaporative emission control system is used to prevent petrol vapours from escaping into the atmosphere from fuel tank.

See Figure 93. The canister (1) collects the fuel vapour from the fuel tank and then the fuel vapour is drawn into the engine for re-burning to avoid pollution caused by the fuel vapour diffused into the air.



Figure 93. Canister

POLISHING OF VEHICLE

After washing your **H-D X440T**, wax all painted surfaces (except matte painted surfaces) using a commercially available polish/quality liquid or paste wax to finish the job. Use only a non abrasive polish or wax made specifically for automobiles. Apply the polish or wax according to the instructions on the container.

NOTE

Polishing or waxing is not applicable for models having matte paint.



1. STARTING TROUBLE - ENGINE DOES NOT START

A. Integrated Start-Kill Switch

Check engine stop switch position

“ON” (⊖) position

“OFF”

Turn to “ON” (⊖) position

Consult an Authorized dealer

B. Side Stand Engine Kill System

Check side stand in gear condition (**page 57**)

Side stand “Up”

Side stand “Down”

Move the side stand up

Consult an Authorized dealer

C. Fuel System

Check fuel gauge

One segment blinking

Refill the fuel tank

Key “ON” position

Check fuel lines

Leakage

Consult an Authorized dealer

OK

Check for operating sound of fuel pump

Broken fuel pump wire connector

Secure connections

OK

Consult an Authorized dealer



D. Electric Starter Not Working

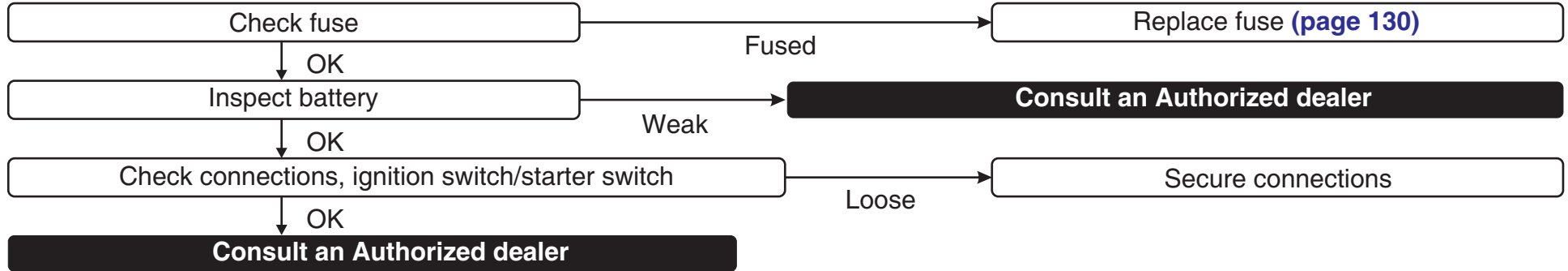

E. No Spark At Spark Plug

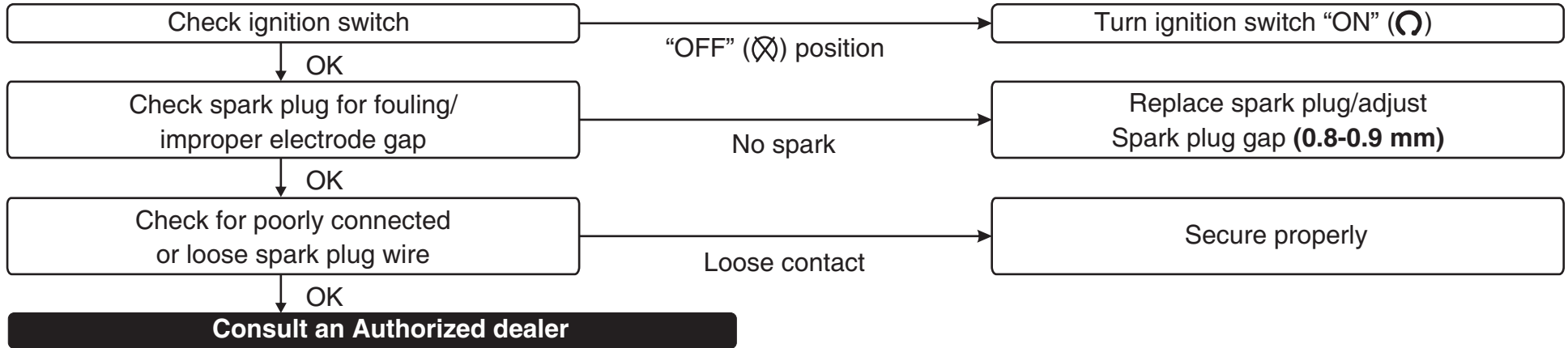

2. ENGINE STARTS BUT STALLS

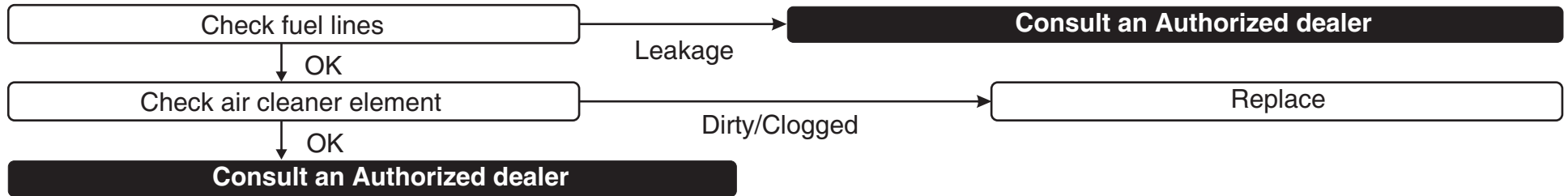

3. POOR PICK UP

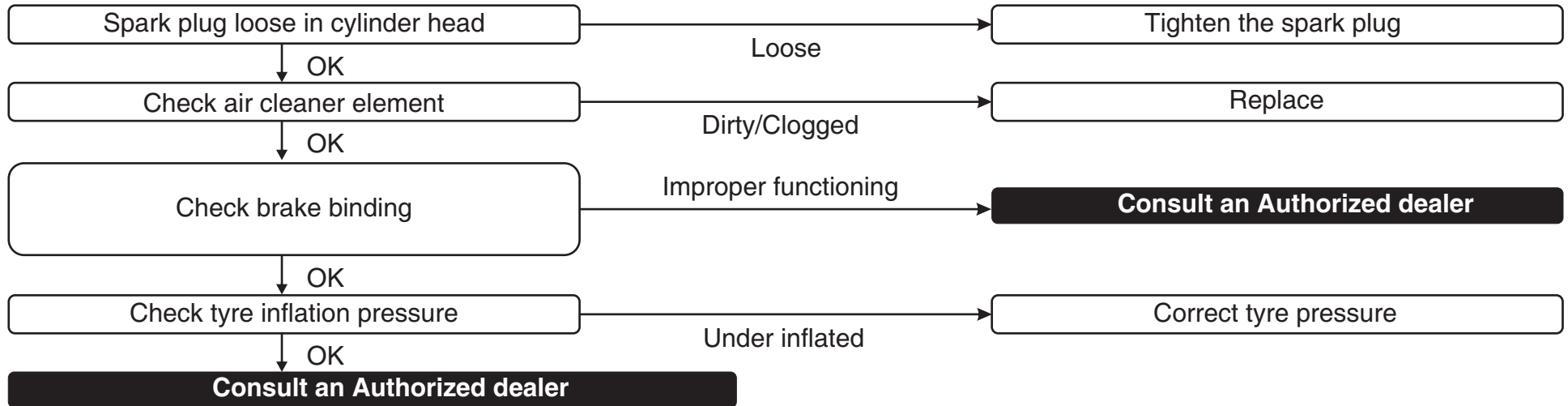

4. ELECTRICAL SYSTEM

Feeble Horn Sound or No Light

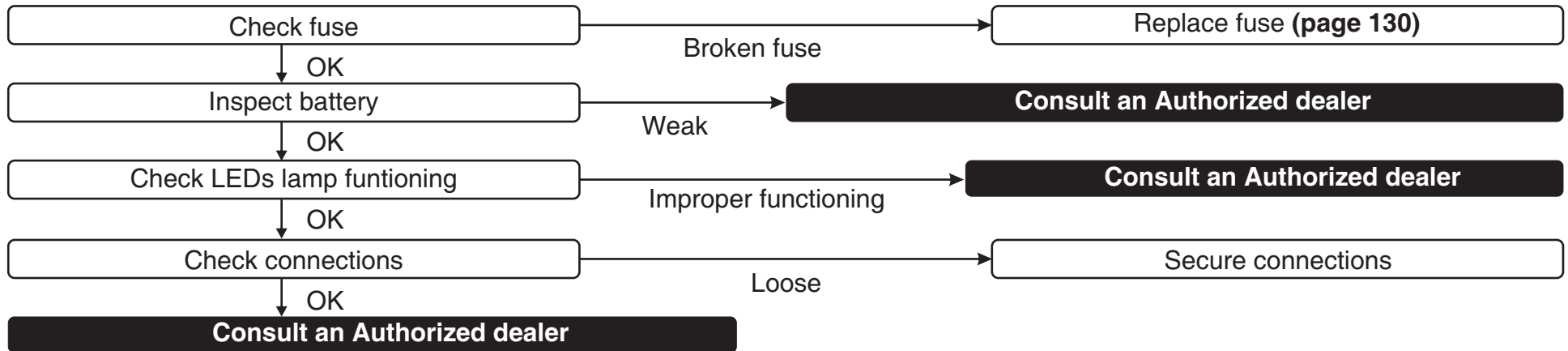

ROAD SIGNS



Mandatory signs: These road signs inform drivers/riders of the traffic rules that apply on a certain stretch of road, thereby instructing them on how to drive/ride. Mandatory signs are distinguished by the bright red circle with black and blue markings. It is imperative that all riders follow these signs as they help avoid accidents. Their violation can be penalised under the Motor Vehicle Act.

Mandatory

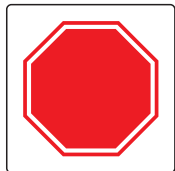

Stop

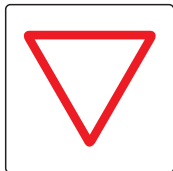

Give Way



One Way



No Horn



No Bicycles



No Automobiles



No Hand Cart



No Pedestrians



No Right Turn



No 'U' Turn



Overtaking Prohibited



Speed Limit

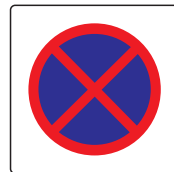

No Stopping or Standing

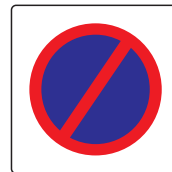

No Parking



Length Limit



High Limit

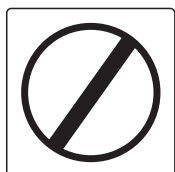

Restriction Ends

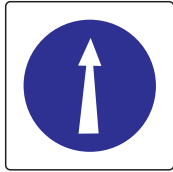

Compulsory-Ahead Only

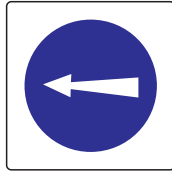

Compulsory-Turn Left



Compulsory-Right Ahead

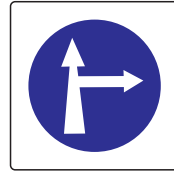

Compulsory-Ahead or Turn Right

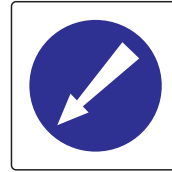

Compulsory-Keep Left

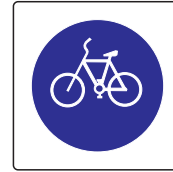

Compulsory-BicycleTrack

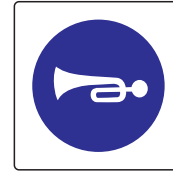

Compulsory-Sound Horn















ROAD SIGNS



Cautionary signs: These signs inform the driver/rider of the road conditions ahead. Cautionary signs therefore serve as a warning. They are usually in a red triangle with black pictures on a white background. Illustrations, diagrams and symbols are used to forewarn about dangers ahead. Cautionary road signs are as important as mandatory signs. However, the violation of cautionary signs does not attract penalty.

Cautionary

















							
Right Hand Curve	Right Reverse Bend	Incline Ahead	Narrow Road Ahead	Narrow Bridge	Pedestrian Crossing	School Ahead	Gap in Medium
							
Cross Road	Men at Work	Roundabout	Hump Road				

ROAD SIGNS



Informatory signs: These are facility signs that provide important information about road directions are maps of specific destinations. On highways, they provide information about the location of public telephones, restaurants, hospitals, parking, petrol pumps, resting-places and more. These signs are usually rectangular, with black or white pictures on a blue background.

Informatory

							
Destination Sign	Hospital	First Aid Post	Petrol Pump	Eating Place	Resting Place	Public Telephone	Place Identification Place
							
Destination Sign	Light Refreshment	Taxi Stand	Parking Both Sides	Parking This Side	No Through Road	No Through Side Road	Re-assure Sign

Signs and Signals are language of the road. Learn them, respect them.



NAVIGATION SIGNS

Navigation signs: HD App and meter console of your H-D X440T will display step by step navigation guidance/direction through below navigation signs when your H-D X440T is in navigation mode with your smartphone.

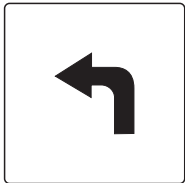

Turn Left

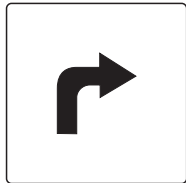

Turn Right

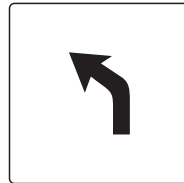

Turn Slight Left

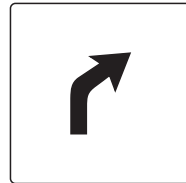

Turn Slight Right

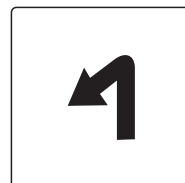

Turn Sharp Left

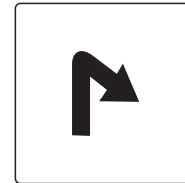

Turn Sharp Right

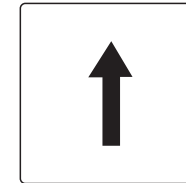

Straight

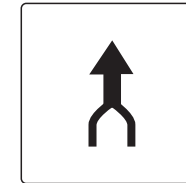

Merge

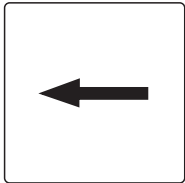

Keep Left

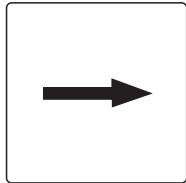

Keep Right

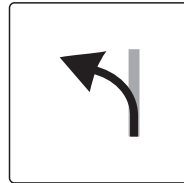

Ramp Left

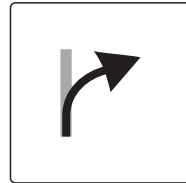

Ramp Right

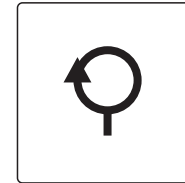

Round About Left

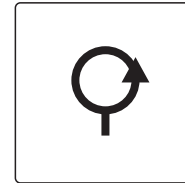

Round About Right

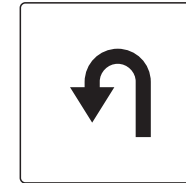

U Turn Left

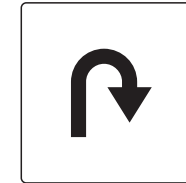

U Turn Right

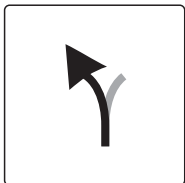

Fork Left

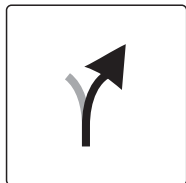

Fork Right



Ferry

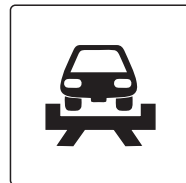

Ferry Train

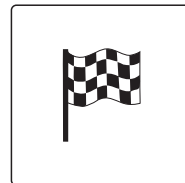

Destination Reached

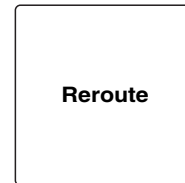

Wrong way

Reroute



NOTES



WARRANTY

Scope of warranty

Hero MotoCorp Ltd. (hereinafter called 'Hero MotoCorp') warrants the **HARLEY-DAVIDSON X440T**, assembled/manufactured in its Plants and sold through its channel partners, to be free from any defect - both in material and workmanship, under normal use and conditions, subject to the following terms & conditions.

Terms & conditions

- a) **H-D X440T** vehicle is warranted for a period of **5 years or 70000 Km**, whichever is earlier, from the date of purchase, emission warranty is separately covered under the head of "Emission Warranty".
- b) It is advised that the purchaser avails all free and paid services from the Authorized workshop as per the recommended schedule, to be eligible for warranty benefits. Each paid service should be availed within 12 months from the date of previous service or as per the recommended schedule, whichever is earlier.
- c) If any problem is observed in **HARLEY-DAVIDSON X440T** by Hero MotoCorp's only obligation/ liability is to repair or replace that part/those parts which is/are considered to be the cause of such problem, provided however that such problem has not resulted due to misuse/improper handling etc. of the vehicle. Any **H-D X440T** vehicle needing repair should be brought along with Owner's Manual to Hero MotoCorp's authorized workshop for necessary inspection and carrying rectification job.
- d) It is clarified that the Warranties given in this Owner's Manual are not binding on Harley Davidson Inc. or any of its affiliates.



LIMITATIONS OF WARRANTY

The warranty shall not apply—

- (1) If all free services/paid services/oil top-ups are not availed as per the recommended schedule at Authorized workshop.
- (2) If any other engine oil which is non compatible with the product is used other than 100% Synthetic SAE 15W 50.
- (3) To normal wear & tear and ageing of components including (but not limited to) brake shoes/pads, clutch plates, drive chain & sprockets, bulbs, electrical wiring, filter, spark plug, fasteners, shims, washers, oil seals, gaskets, rubber parts, bush, rubber bellows, plastic parts breakage, wheel rim for misalignment/bend, steering ball race & cone, control cables such as brake cable/clutch cable, fuses (all types), steering handle for bend and sticker peel off.
- (4) If additional wheel(s) is/are fitted and/or any other modification carried out/unauthorized accessories fitted which shall be responsible for malfunction/deterioration of the vehicle or modifications/ alterations are made to the vehicle which are not permissible under applicable laws, or modifications, alterations, tampering or improper repair are undertaken at unauthorised workshops.
- (5) If any modifications/alterations/repairs are made to the vehicle which are (a) not as per applicable laws, and/or (b) are undertaken at unauthorized workshops.
- (6) If there has been any tampering or improper repair undertaken.
- (7) If **H-D X440T** vehicle has been used in any competitive events like races or rallies or for any commercial purposes or if any damage results from misuse or use beyond the limitation of the intended purpose or any damage due to use under abnormal conditions.
- (8) To any damage on vehicle's painted surface cropping due to industrial pollution or other external factors.
- (9) For normal phenomena like noise, vibration, oil seepage etc., which do not affect the performance, quality and/or function, of the vehicle.
- (10) To any damage caused due to usage of improper oil/grease and/or non-genuine parts.
- (11) If any defect crops or repairs needed as a result of using adulterated fuel.
- (12) If any maintenance/repairs required due to bad road conditions or misuse of **H-D X440T** vehicle or required due to operation or use of the vehicle at any place or for such purpose for which the vehicle is not designed or manufactured.
- (13) If any defect crops or repairs needed as a result of **H-D X440T** vehicle meeting with some accident.
- (14) For consumables like oil, grease, gasket etc to be used during free services and/or warranty repairs.
- (15) If any damage results from repair, adjustment or maintenance operations by any method other than the methods specified by Hero MotoCorp.
- (16) If any damage results from operation, whether intentional or accidental, other than as specified in the Owner's Manual.



- (17) To electrical components such as bulbs, fuses, electrical wiring cut due to external reasons (Rat bites etc.).
- (18) Any cost for periodic maintenance such as cleaning, inspection and adjustment.
- (19) To any part of the **H-D X440T** vehicle which has been tampered or repaired in such a manner which has resulted in malfunction of the vehicle.
- (20) For **H-D X440T** vehicle not used in accordance with the guidelines given in this Owner's Manual.
- (21) To proprietary items like tyres, tubes, batteries, etc, as they are subjected to the warranty terms & conditions of the respective manufacturers and directly handled by them only.
- (22) Any defect(s) developing on account of external factors such as environmental factors; including but not limited to fading/peeling/rusting of paint and/or stripes and/or plated parts, seat leather tearing & cracking, aluminum parts oxidation and cracking & discoloring of control switches etc. or any damage resulting from soot and smoke, use of chemical, bird droppings or damage by sea water, sea breeze or salt.
- (23) If any damage results from operation, whether intentional or accidental, other than as specified in the Owner's Manual.
- (24) If the odometer of **H-D X440T** has been altered or tampered.
- (25) If the Vehicle's Identification Number (VIN) or Engine number has been altered or removed, or any circumstances exist that makes it difficult or impossible to establish the true history, origin and warranty coverage of the vehicle or part in question.
- (26) If any damage is caused due to a force majeure event, such as flood, fire, terrorist act, etc.

Hero MotoCorp shall not be liable for (a) any incidental, indirect or consequential damages/loss of any kind whatsoever, and (b) any delay in servicing beyond its control or the control of its authorised dealerships/workshops.

This warranty is only given by Hero MotoCorp and no employee, dealership, workshop or any other person is authorised to extend the warranty provided herein. Hero MotoCorp's obligation under this warranty shall be limited to repairing or replacing, free of cost, those parts of the vehicle which upon examination by the Hero MotoCorp may prove to the satisfaction of Hero MotoCorp to have a manufacturing defect.

Hero MotoCorp's **obligation under this warranty shall be limited to repairing or replacing, free of cost, those parts of the vehicle which upon examination by Hero MotoCorp may prove to the satisfaction of Hero MotoCorp to have a manufacturing defect. Decision regarding warranty settlement shall be taken by Hero MotoCorp and the same shall be final and binding on all concern. Subject to DELHI JURISDICTION only.**



BATTERY WARRANTY

Battery fitted in **H-D X440T** is a proprietary product of the battery manufacturer and shall be fulfilled and handled directly by the battery manufacturer; Hero MotoCorp shall not be liable for the same. The battery warranty shall be for the period and governed by the terms and conditions as mentioned herein below:

Warranty Period:

The battery is warranted by the battery manufacturer for a period of 18 months from date of sale of vehicle or 20000 km whichever is earlier.

Terms and conditions of warranty

1. Batteries are warranted against all defects in material and workmanship. Liability under this warranty is limited to making good of defects arising solely from the use of faulty material or workmanship during manufacturing and developing under proper use.
The warranty commences from the date of delivery to the original purchaser of the vehicle.
2. In the event of any complaint the battery is to be returned complete with electrolyte to nearest battery service station or to the dealer. On inspection, battery will be returned or replaced.
3. This warranty card accompanies a battery sold as OEM fitment only. Claims should be supported with vehicle purchase invoice to enable processing.
4. The right to determine whether a battery needs repair or total replacement lies with the battery manufacturer. In case where the battery is replaced, the defective battery becomes the property of the company and no scrap rebate will be given for it. The warranty period on the battery being repaired/replaced shall commence from the date of sale of the original battery as stated in the original warranty card.
5. All liabilities under this warranty will cease if the battery is used on the vehicle other than that on which the battery was originally fitted and on the expiry of the warranty period as mentioned above.
6. Recharging is not covered under the purview of this warranty and shall be billed as extra. However, free of cost (FOC) battery replacement/ repair includes cost of charging.
7. This warranty does not cover damage to the battery caused by faulty electrical systems, incorrect charging and filling, improper handling of the battery by unauthorized dealers/auto electricians, maintenance, willful abuse, destruction by fire, collusion, theft or recharging.
8. Breakage of container and cover do not come under the purview of this warranty.
9. Adjudication and settlement of claim will take a couple of days as a battery has to be tested for the reported failure.
10. In case of tampering of the original wiring circuit in any manner whatsoever.
11. If a battery which is not recommended is fitted on the vehicle then such battery will not carry any warranty.
12. The applicable taxes which is leviable on the battery under repair or replacement will be borne by you (the customer).
13. You (the customer) are deemed to have read, understood and agreed to these conditions at the time of purchase of the vehicle.

130 Warranties



EMISSION WARRANTY

Scope of warranty

Hero MotoCorp Ltd. warrants all its vehicles, assembled/manufactured at its various Plants and sold through its channel partners, to comply with emission standards as specified in sub rule (2) of Rule 115 of Central Motor Vehicles Rules, 1989, subject to following terms & conditions.

Terms & conditions

- a) The emission warranty shall be applicable in India and shall remain valid for a period of 3 years or 30000 km, whichever occurs earlier, from the date of vehicle purchase.
- b) The parts, which are covered under emission warranty are fuel injector, fuel pump, throttle body, ignition coil, oxygen sensor and muffler (“Emission Related Component(s)”).
- c) In case any defect is observed in any Emission-Related Component(s) which are covered under emission warranty, Hero MotoCorp's only obligation/liability shall be to repair and/or replace those part (s) which is/are considered to be the cause of non-compliance with the emission standards.
- d) The method (s) of examination to determine the warranty conditions of the Emission Related Component will be at the sole discretion of Hero MotoCorp and / or its channel partners / service center and result of such examination shall be final and binding. If on examination the warranty conditions of the Emission Related Component is / are not established, Hero MotoCorp will have the right to charge all, or part of the cost of such examination / service charges to you in addition to the cost of the components.
- e) Hero MotoCorp shall have the sole discretion to decide to replace the defective Emission Related Component or the entire assembly or any other part required for such repair.
- f) The emission warranty shall be applicable only to those vehicles, which are being regularly maintained in accordance with the maintenance schedule provided in the Owner's Manual.
- g) You should follow the recommended parts replacement as per the maintenance schedule in order to avail the emission warranty.
- h) If any Emission Related Component is/are tampered and/or repaired by unauthorized person/ workshops etc, then the emission warranty shall stand cancelled.
- i) Any Emission Related Component suffering from wear and tear under the normal course of running shall not be covered under the emission warranty. Therefore, all such parts should be replaced by you from time to time, on payment basis, as per the maintenance schedule provided in Owner's Manual and dealer's advice



EMISSION WARRANTY

- j) It is recommended to avail the services as per the recommended schedule to be eligible for the emission warranty benefits. Please ensure that each paid service is availed within 12 months from the date of previous services or as per the recommended schedule, whichever is earlier. All service details should be completely filled by the dealer, in the Service Record Sheet given in the Owner's Manual.
- k) It is mandatory to obtain a PUC certificate from the authorised PUC center. In case of non-compliance with the emission standards please contact the channel partner/authorised workshop immediately along with the previous OK certificate, for the necessary rectification. The manufacturer or the dealer is not responsible for any penalty levied on you on account of non-compliance with the emission standards.
- l) Emission warranty shall not be applicable if
- The vehicle has been subjected to abnormal use, abuse, neglect and improper maintenance or has met with an accident.
 - The vehicle, or parts including the Emission Related Component(s) thereof, has been altered, tampered with or modified or replaced in an unauthorized manner.
 - The odometer is not functioning or the odometer and/or its reading has been changed/tampered with, so that the actual distance covered cannot be readily determined.
 - The vehicle has been used for competitions, races, and rallies or for the purpose of establishing records.
 - If any damage results to the Emission Related Component(s) covered under from repair, adjustment or maintenance operations by any method other than the methods specified by Hero MotoCorp.
 - If any damage results from operation, whether intentional or accidental, other than as specified in the Owner's Manual.
 - Any cost for periodic maintenance such as cleaning, inspection and adjustment.
 - If any damage is caused to the Emission Related Component(s) due to a force majeure event, such as flood, fire, terrorist act, etc.
- m) All decisions regarding emission warranty settlement shall be taken by Hero MotoCorp and shall be final binding on all concerned.

Subject to Delhi jurisdiction only.



X440T MODEL

2025 HARLEY-DAVIDSON® OWNER'S MANUAL



Contact Harley-Davidson Business Unit at:
Hero MotoCorp Limited, The Grand Plaza,
Plot No.2, Nelson Mandela Road, Vasant Kunj -
Phase -II, New Delhi - 110070.